

MALUNO

# MALUNO

General Catalogue 2024



**Curtain Wall System**

24

**Opening System**

30

**Unitized System**

36

**Window & Door System**

58

**Window & Door System**

66

**AKW 53**

**AKW 63**

**Window & Door System**

74

**Hidden vent window System**

82

**AKW 73**

**Lift & Slide System**

42

**Slide and Lift & Slide System**

50

**AKL 140**

**AKS 90**

88

## Exporting to Several Countries



۱. دارای گواهینامه فنی از مرکز تحقیقات راه مسکن و شهرسازی
۲. دارای علامت استاندارد ایران
۳. واحد نمونه صنعتی استان مرکزی در سال ۱۴۰۰
۴. واحد نمونه صنعتی کشوری سال ۹۶
۵. واحد نمونه صنعتی استان مرکزی در سال ۹۵
۶. واحد صاعی و تلاشگر استان مرکزی در سال ۹۴
۷. واحد نمونه صنعتی استان مرکزی در سال ۹۳
۸. واحد نمونه صنعتی استان مرکزی در سال ۹۲
۹. واحد نمونه صنعتی استان مرکزی در سال ۹۰

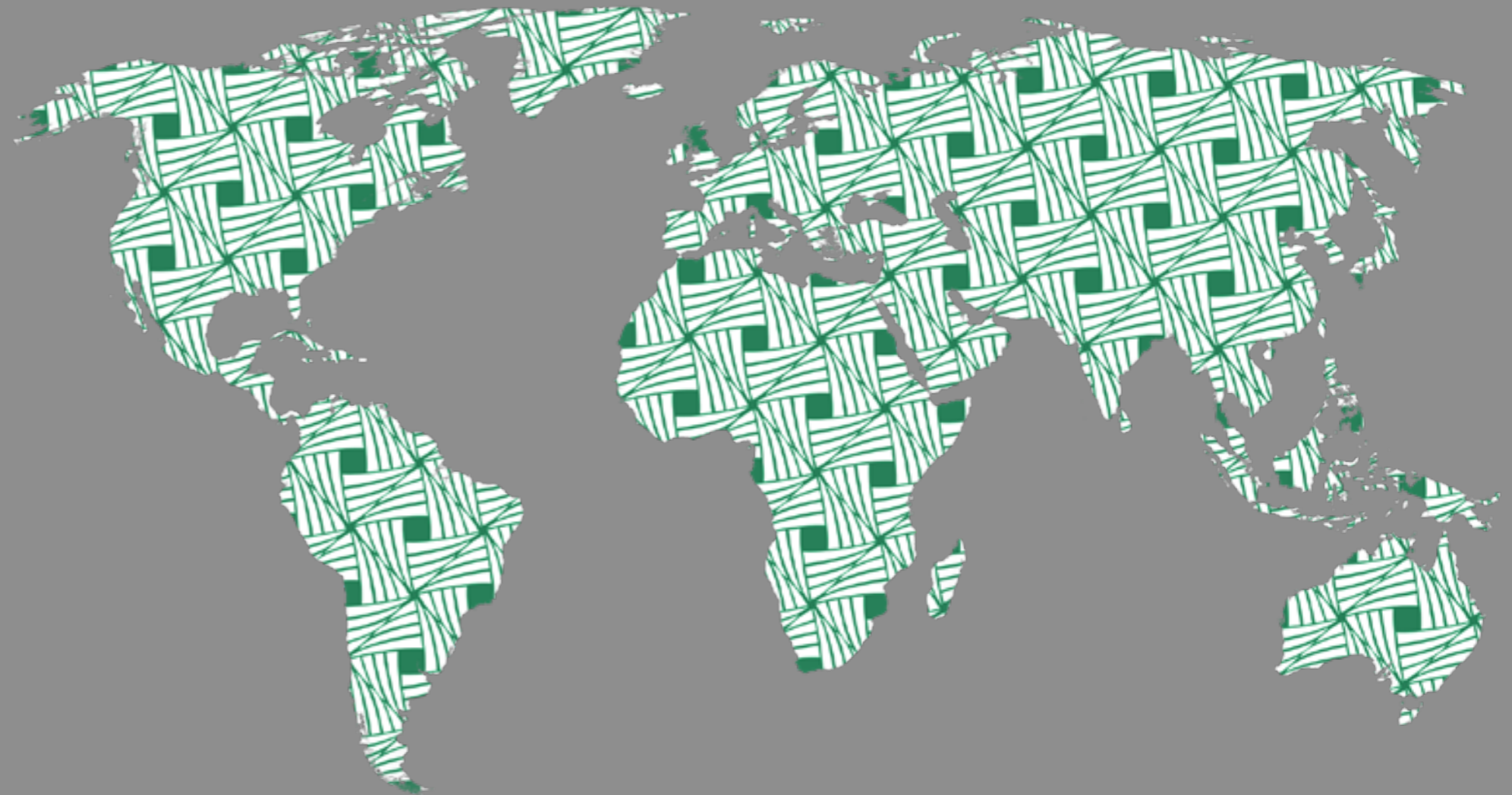

## ALUMROLL NOVIN CO.

- The biggest Aluminium Profile Exporter of Iran
- The First and Biggest Aluminium Exporter to CIS Region
- 77.6 Percent Growth of Exports in First Six months of 1401 , Compared to the Same Period in 1400
- The Solo Exporter of Aluminium Profiles to Europe and Africa
- The Solo Exporter of Aluminium Products to Syria
- Member of Joint Chambers of Commerce (between Iran and other countries)



---

## Introduction of ALUMROLL NOVIN CO.

---



The background of Sanaye Alumroll Novin Co. in field of aluminium dates back to 1973, when the Alumroll factory was established in Arak. At that time, Alumroll factory used to be named as one of the greatest producers of aluminium profiles in Iran and middle east for many years, by using the best and latest aluminium billetcasting and homogenizing systems and SCHOLEAMANN modern extrusion presses.

However, with increasing the market's quality/quantity demand, the existing facilities of the company was not sufficient to meet the expectations of the customers and it ceded a part of the market to its competitors.

After Iranian government cession of the company to the private sector in 2008, the technical and commercial facilities of Paradise Aluminium Industries – new owner – was utilized to restart the production lines, modernization of machineries and adding new production equipment including powder coating lines and extrusion presses, the company regained its position in production of aluminium products, not only in architectural applications, but also in industrial and non-constructional sections, under the new name of 'Sanaye Alumroll Novin Co.'

Anyway, due to expanding of using aluminium metal in different industries and vital need to enhance the quality of aluminium products by means of establishing modern and up-to-date production lines and latest technologies in order to meet the local and international market demands, preventing raw-sale, increasing value-added and obtaining the capability of competition in international markets, and since the company was located in an urban area and it was not possible to develop the production spaces, the initial studies of construction of the first and the biggest exclusive aluminium industrial town of the country started in an area of 36 hectares. Around 25 hectares of this area is allocated to Sanaye Alumroll Novin company and the rest is for Ravan Godaz Pardis company. The first phase of Sanaye Alumroll Novin Company has %70 progress and the rest of the project is underway. Furthermore, after technical and commercial negotiations with a large number of reputable global suppliers of machineries and technologies in the field of Aluminium, the first phase of Ravan Godaz Pardis company was started with construction of 21,000 square meter of production halls, and importing various machineries and production lines afterwards. This plan included updating and upgrading production plants including cast house, die shop, extrusion, anodizing, powder coating and sublimation and know-how transfer in different fields based on which the first phase has been completed and is in operation.



## Casting Plant



In the framework of the first phase of development plan, the 30 ton and 50 ton capacity tiltable melting/holding furnaces, 160 ton/day capacity airslip billet casting system, 240 ton/day capacity aluminium billet homogenizing plant with automatic stackers and de-stackers, cutting, marking, bundling and packing and weighting systems were installed.

The machineries of this plant use the latest technology in the world, including:

- Regenerative burners for better thermal performance and saving energy up to %30
- Furnace atmosphere control system
- Porous plugs for degassing from the bottom of the furnaces
- Airslip casting system for 6 to 10 inch billets which has been used for the first time in Iran
- Fully automatic billet stackers and de-stackers
- Batch type 40 ton/batch capacity homogenizing furnaces
- Homogenizing stabilizer system with 40 ton/batch capacity cooling cabinets
- Long and short billet cutting systems
- Robotic bundling section
- Automatic marking and weighing devices

## Extrusion Die Designing, Manufacturing and Heat Treatment Plant

The company's die shop is unique in the country in terms of work space, equipment and capacity. Using high quality European hot work tool steel bars (especial for making extrusion dies) purchased directly by foreign trade department of the company, modern software for designing, simulating the dies and CNC machineries, together with the expertise of the engineering department, the company is capable to design, manufacture and maintain all kind of industrial and architectural extrusion dies, required in the field of extrusion industry, up to a diameter of 530 mm.

Furthermore, taking the importance of correct heat treatment and nitration process on extrusion dies and its essential effect on their quality and lifetime into consideration, the heat treatment process is done on extrusion dies by modern furnaces. In addition, to reach the surface hardness of extrusion dies the nitriding process is performed by the most modern gas nitration furnace inside the company in accordance with the latest international standards.

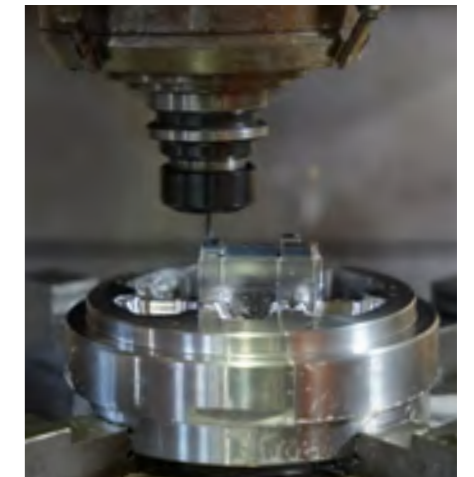

## Extrusion Plant

Log preheating furnaces with hot shears/hot saws, batch type die heating ovens, complete set of European extrusion presses including 2 x 1450 ton 6-5 inch, 2 x 2000 ton 8-7 inch, 1 x 2500 ton 10-8 inch and 1 x 3150 ton 12-10 inch machines equipped with latest hydraulic and automation systems, quenching systems, run-out tables equipped with double pullers, semi-automatic stretcher and cold saw machines are used in extrusion lines in order to produce aluminium sections in alloy groups 7000-1000 with the maximum width of 400 mm. In addition, the ageing process is done in 24 ton/batch capacity ageing ovens for the profiles to the length of 14 m.



## Heat Treatment and Cold Working Plant



This plant utilizes 3 sets of vertical solution treatment furnaces, equipped with high speed quenching system, advanced air circulation and temperature uniformity controlling methods and combustion air separation system from load chamber, enabling it to perform solution heat treatment process on all roll milling and casting alloys to the length of 3.5 meters and width of 1 meter. In addition, electrical and gas heated ageing furnaces equipped with uniform air circulation and temperature precise control are used to perform ageing process on different aluminium alloys.

---

## Anodizing Plant

---



Nowadays, with expanding the use of aluminium profiles in construction and other industries together with the evolution of aluminium market and extensive changes in taste and demands of customers, the natural anodizing and electro coloring surface treatment processes are considered as one of the most important parts of aluminium profile production chain. These procedures not only have technical and protective roles, but also are one of the decorative aspects of aluminium profiles. Having a modern anodizing plant becomes even more important when it is understood that achieving required quality needs permanent control on all relevant parameters like electric current, anodizing layer thickness and color uniformity and high quality chemicals together with chemical composition control.

One of the problems which many of anodizing plants face is the failure in controlling the color uniformity, which cannot be solved even with utilizing the anodizing fixed factors, due to the manual nature of the operations and human errors.

Realizing this and to meet the quality appropriate to the demand of customers and achieve the required production capacity, the company installed a fully automatic anodizing line with capacity of 60 tons per day, manufactured by most reliable European supplier. As the biggest and newest one, this QUALANOD authenticable plant is the pioneer of quality/quantity in the country and one of the few samples of this line in the middle east and west Asia regions, which can provide different surface treatment processes on aluminium profiles such as electro coloring, chemical polishing, immersion coloring in four different colors simultaneously. In addition, by utilizing various machineries / devices, it is able to perform anodization coating with various patterns on different sections.

---

## Powder Coating Plant

---

One of the other methods of surface coating of aluminium profiles is using polymer compositions by spraying polyester and epoxy polyester powders electrostatically on profile surfaces and processing the powder in baking furnaces in the temperature of 200~180°C. Due to unlimited variety of colors and designs of powders, this process offers a wide range of options to the customers. The 2 electrostatic powder coating plants of the company are the biggest and most equipped powder coating plants in the country and perform powder coating of aluminium profiles to the length of 14 meters and capacity of 60 tons per day in different colors and designs.

---

## Sublimation Plant

---

The application of aluminium profiles in construction industry and interior architecture necessitates to create diversity in painting, among which wood, marble, flowers and even natural landscapes can be mentioned. This process is generally named as sublimation. In this method, the desired surface is first covered by polyurethane weathering resistant materials. Then the film containing the desired design is pulled over the profile. Profiles are heated for 10 minutes in 200°C in special furnaces, in order to stabilize the design on the powder coating layer.

The sublimation unit of the company uses very modern fully automatic machineries made by SEF ITALIA, to produce 30 tons/day of various aluminium sections and plates with different designs.



## Thermal Break Profiles Production line



The thermal break profiles used in construction industry are produced in this line. The knurling, inserting polyamide strings and sewing process are done fully automatically. One of the most important factors in manufacturing thermal break profiles is the quality of the polyamide profiles and sewing process, so the polyamide string to be inserted inside aluminium profile correctly and tight. This advantage has been achieved by means of advanced machineries and improving the quality of the polyamide strips by producing them inside the holding, according to the international standards. The quality of sewing process is inspected through continuous sampling and testing in special devices by applying appropriate pressures and checking the results.

In addition, in order to ensure the quality of needed polyamide sections, the company installed two polyamide extrusion lines, purchased from one of the reliable suppliers. So the required sections are produced inside the company from the best raw materials.

## Quality Control

Beside the production facilities which are needed to achieve the desired capacity, quality control and continuous improvement has always been of the company's concerns. Especially, when this company is responsible for supplying materials and products to a wide range of industries, based on various standards. Fulfilling these expectations is possible only through implementation of precise quality instructions and permanent monitoring of production procedures. In this company, the quality control experts are responsible for monitoring and inspecting all production procedures and their products from beginning to the end in frame of appropriate standards, to ensure that any process and product comply with quality requirements. Considering the scope of company's production activities, the quality control unit employs advanced metallurgy, chemistry and powder coating laboratories in which in addition to the input raw materials, the quality of all produced products of production lines are inspected according to the international standards and customer requirements in order to ensure customers satisfaction and continuous improvement of production procedures.





The metallurgy laboratory of the company is one of the most advanced samples of the country in the field of aluminium which is able to investigate all metallurgical, physical and mechanical specifications of metallic materials, using the following equipment:

- Online hydrogen measuring device produced by one of the most reliable European manufacturers for measuring and controlling hydrogen content in liquid aluminium
- Advanced spectrometer device able to identify and measure the lowest amount of more than 30 effective elements of aluminium alloys
- Tension, pressure and bending test device in order to check the mechanical specifications of casted alloys
- Metallography and polarization microscope to check the microstructure of produced materials and sections
- Automatic twin cutting and polishing device for preparation of metallography samples
- Ultrasonic test device for nondestructive test of internal defects
- Electrical conductivity measuring device
- Stationary and portable hardness testers for checking the hardness of aluminium sections
- Various and precise dimensional measuring equipment
- Microhardness device in order to control the hardness of surface of the aluminium dies
- The salt spray machine in order to control the quality of the powder coating layer against corrosion
- Color-meter device for inspection of the color quality and specifications
- Glossy-meter device for checking the gloss of the colors
- The cross-cut device to check the stickiness of the powder coating to the aluminium profile surface
- The thickness-meter device for measuring the thickness of the powder coating layer

In Chemistry laboratory, the effective factors of the process especially the content of chemicals in the tanks is measured continuously to meet the quality demanded by customer and required by the standards. In addition, the electro anodizing color spectrum, the anodizing layer thickness and the quality of sealing layer is controlled continuously by means of advanced equipment and according to QUALANOD standard requirements.

Furthermore, in the powder coating laboratory, the quality of the input powders is controlled by laboratory spraying guns and ovens before sending to production lines. Moreover, the thickness of powder coating layer, gloss value and powder adhesion to the metal surface according to the QUALICOAT standard are other tests performed in this laboratory.

Due to the high quality of the products, this holding, as an IMS qualified complex, this holding has been able to achieve technical certification of the ministry of roads and urban development ISO 9001, ISO 14001 and ISO 45001 standards.

## Parts and Machineries Manufacturing Plant



One of the desired goals of implementing production lines through international non-Iranian suppliers, in addition to the improve the know-how of construction of the machineries and using the existing knowledge in the holding, in order to procure the best and highest quality machineries, is to create joint projects, through which only those critical parts and accessories that cannot be manufactured or found locally are supplied by foreign supplier and other parts such as steel structures and different components will be provided by Alumroll, according to technical specifications and under supervision of supplier. That facilitates designing and manufacturing know-how transfer and increasing technical capability of this company. For this purpose, this company launched its parts and machineries manufacturing plant, in 2017. This plant performs all designing and manufacturing activities for different parts of its construction and renovation projects, using a wide range of facilities like cutting, lathe, welding, grinding, test and painting machineries.

---

## Logistics

---

In order to maintain an on time delivery and prevent any damage to the products during transportation, the company uses its wide transportation network including trailers, trucks and pickups not only for covering domestic deliveries, but also for sending the products to different countries such as Iraq, Afghanistan, Turkey, Armenia, Turkmenistan and ...



---

## Research and Development

---

In addition to achieving the latest machineries, equipment and technologies around the world in the field of producing aluminium sections, the R&D department of the company try to provide the customers with the best services through constant connection with reputable production companies and the provider centers of technical knowledge and know-how transfer, around the world.

One of the company main goals within the framework of the R&D activities is providing new systems for constructional and architectural profiles and their accessories based on climate, geography and culture of Iran and according to the latest international standards. To this end, a team of experts of the company was assigned to conduct extensive studies for designing and executing of those systems in consultation with most reliable Iranian and non-Iranian companies, led to design of a series of new profile systems. In the near future, the manufacturing, production and standard tests will be completed and the systems will be available for construction companies and other end-users via ORGADATA software.





# **FACADE** **System**

# MALUNO

## STICK CURTAIN WALL

Curtain wall system is a type of exterior cladding system commonly used in modern architecture. Here's a breakdown of its key features:

- **Curtain Wall:** A curtain wall is a non-structural exterior wall cladding system that is designed to support its own weight and resist environmental forces such as wind and rain. It is typically composed of aluminium framing, glass panels, and sometimes other materials like stone or metal panels.
- **System:** The aluminium curtain wall system comprises various components, including:
- **Aluminium framing:** This forms the skeleton of the curtain wall and provides support for the glass or other cladding materials.
- **Glass panels:** These are the primary infill material of the curtain wall and can vary in thickness, type (clear, tinted, reflective), and configuration (single, double, or triple glazing).
- **Sealants and gaskets:** These are used to weatherproof and seal the joints between aluminium framing and glass panels, preventing water infiltration and air leakage.
- **Thermal breaks:** Aluminium curtain wall systems may incorporate thermal breaks—insulating materials between interior and exterior aluminium sections—to improve energy efficiency and reduce heat transfer.
- **Applications:** Aluminium curtain wall systems are commonly used in commercial, institutional, and high-rise residential buildings. They are favored for their aesthetic appeal, versatility, and ability to accommodate large expanses of glass, allowing for abundant natural light and panoramic views.

**Advantages,** Aluminium curtain wall systems offer several advantages, including:

- **Architectural versatility:** Curtain wall systems can be customized in terms of design, shape, and color to meet the specific aesthetic and functional requirements of a building.
- **Energy efficiency:** Modern curtain wall systems incorporate thermal breaks and high-performance glazing to enhance energy efficiency and reduce heating and cooling costs.
- **Structural performance:** Aluminium curtain wall systems are engineered to withstand wind loads, seismic forces, and other environmental factors, providing structural stability and safety.
- **Sustainability:** Aluminium is a recyclable material, and curtain wall systems can be designed for easy disassembly and recycling at the end of their service life, contributing to sustainable building practices.

Overall, aluminium curtain wall systems offer an elegant and functional solution for creating visually striking building facades while providing weather protection, energy efficiency, and structural integrity.

# MALUNO

## UNITIZED CURTAIN WALL

Unitized system is a type of curtain wall construction method where prefabricated units or modules are assembled off-site and then transported and installed onto the building structure. Here's a breakdown of its key features:

- **Modular Design:** The unitized system is designed in modular units, typically consisting of aluminium framing, glass panels, and other cladding materials. These units are pre-assembled in a controlled factory environment, allowing for greater precision and quality control.
- **Factory Fabrication:** Each unit is fabricated and glazed in the factory, where specialized equipment and skilled labor ensure consistency and accuracy. This process allows for faster production times and minimizes disruptions to on-site construction activities.
- **Transportation and Installation:** Once fabricated, the unitized modules are transported to the construction site and lifted into place using cranes or other lifting equipment. The units are then connected and anchored to the building structure using mechanical fasteners or other attachment methods.
- **Sealing and Weatherproofing:** Special attention is paid to sealing and weatherproofing the joints between unitized modules to prevent water infiltration, air leakage, and thermal bridging. Sealants, gaskets, and other weatherproofing materials are used to ensure a tight and secure building envelope.
- **Integration with Building Systems:** Unitized curtain wall systems can be integrated with other building systems, such as HVAC, lighting, and fire protection, to create a fully functional and efficient building envelope.

**Advantages,** Aluminium unitized systems offer several advantages over traditional curtain wall construction methods, including:

- **Speed of construction:** Prefabrication of unitized modules allows for faster on-site installation, reducing construction time and labor costs.
- **Quality control:** Factory fabrication ensures consistency and precision in assembly, resulting in higher quality and performance.
- **Improved safety:** Reduced on-site assembly activities minimize the risk of accidents and injuries to workers.
- **Design flexibility:** Unitized systems can accommodate various architectural designs and building shapes, including curves and angles.
- **Energy efficiency:** Tighter seals and better insulation in unitized systems can improve the thermal performance of the building envelope, reducing heating and cooling costs.

Overall, aluminium unitized systems offer a modern and efficient solution for constructing curtain wall facades, providing speed, quality, and flexibility in building envelope design and construction.



# TABLE OF CONTENT

INTRO .....	25
CURTAIN WALL:	
FACE CAP AK50 .....	26
U-CHANNEL (SG) AK50 .....	28

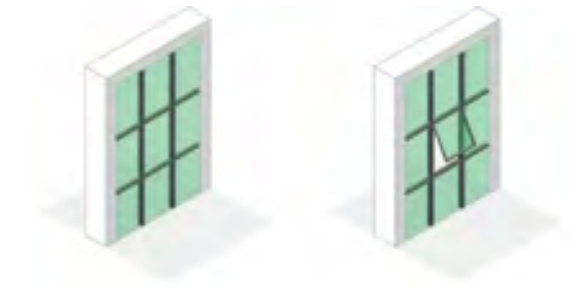

## MALUNO CURTAIN WALL AK 50 SYSTEM

Glass curtain walls can replace your existing solid walls to make an otherwise ordinary room into something spectacular. Aluminium glazed walls effortlessly blur the divide between inside and outside, allowing your living spaces to be filled with panoramic views and natural light. Maluno aluminium curtain walling offers a range of aesthetic solutions, such as different styles of face caps from horizontal to vertical lining, to a more minimalistic look using structural glazing or clamping technologies.

**CURTAIN WALL SYSTEM**

**Face cap AK50**



Technical description	
	Mullion view: 50 mm
	Wall thickness: 3.5-1.6 mm
	The glass thickness width: 38 - 6 mm
	Rubber description: EPDM DIN 7863
	Aluminium alloy extrusion: EN AW 6063 T5
	Thermal barrier: Polyamide 6.6 GF %25
	Thermal transmittance: 2.77-1.82 $\frac{W}{(M^2.K)}$

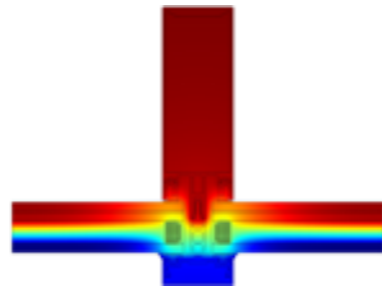
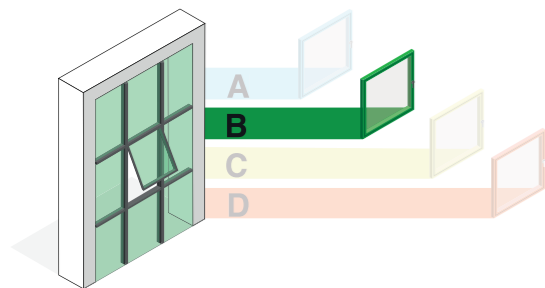

**CURTAIN WALL SYSTEM**

**Face cap (inner threshold) AK50**



**CURTAIN WALL SYSTEM**

**Face cap (outer threshold) AK50**



**CURTAIN WALL SYSTEM**

**Face cap (insertion label) AK50**

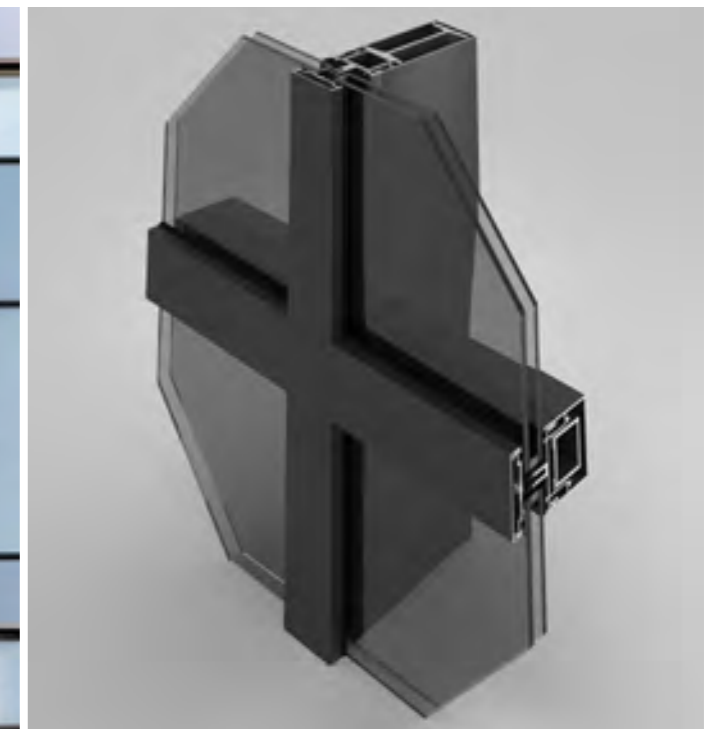



**CURTAIN WALL SYSTEM**  
**U-Channel (SG) AK50**



**Technical description**

The glass thickness width:	6 - 36 MM
Profile view:	50 MM
Rubber description:	EPDM DIN 7863
Aluminium alloy extrusion:	EN AW 6063 T5
Thermal barrier:	POLYAMIDE 6.6 GF %25
Thermal transmittance:	4.3-2.86 $\frac{W}{(M^2.K)}$

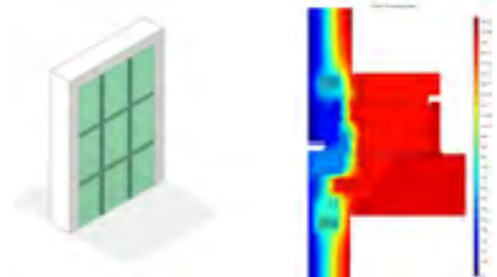
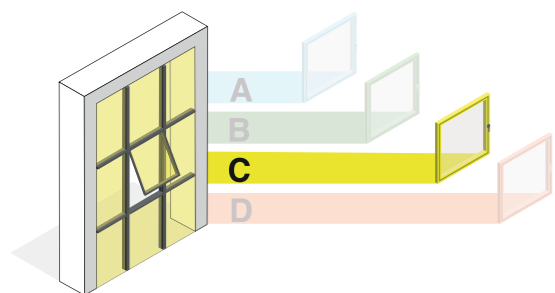

**CURTAIN WALL SYSTEM**  
**U-Channel (inner threshold) AK50**



**CURTAIN WALL SYSTEM**  
**U-Channel (outer threshold) AK50**



# TABLE OF CONTENT

INTRO .....	31
OPENING OF FACE CAP AKV50 .....	32
Parallel OPENING OF FACE CAP AKV50.....	33
OPENING OF U-CHANNEL AKV50 .....	34
OPENING OF U-CHANNEL (SG) AKV50 .....	35

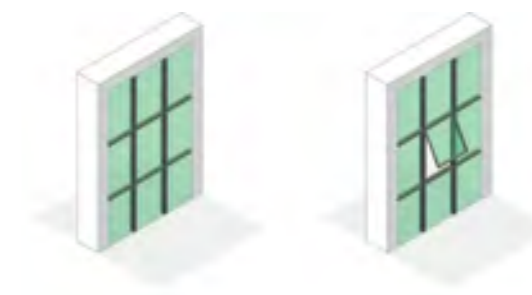

## MALUNO OPENING OF CURTAIN WALL AK 50 SYSTEM

The openings are applicable in both friction and parallel models, designed in accordance with Euro groove fitting standards.



**CURTAIN WALL SYSTEM**  
**Opening of Face cap AKV50**



Technical description	
Vent view:	64 mm
Wall thickness:	1.6-1.8 mm
The glass thickness width:	8,10,32,34,36 mm
Rubber description:	EPDM DIN 7863
Aluminium alloy extrusion:	EN AW 6063 T5
Thermal barrier:	Polyamide 6.6 GF 25%
Thermal transmittance:	2.7 $\frac{W}{(M^2.K)}$

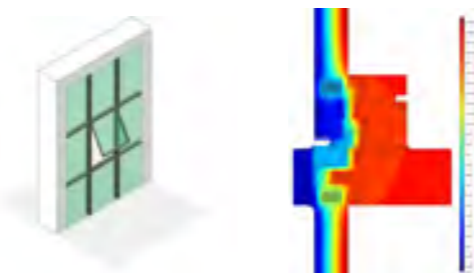
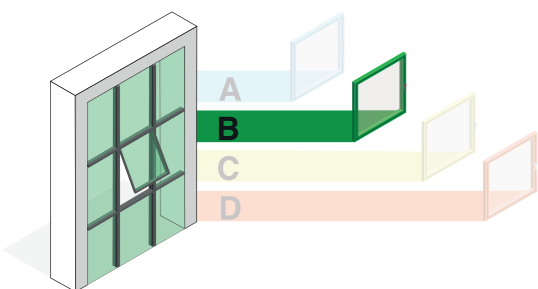

**CURTAIN WALL SYSTEM**  
**Parallel Opening of Face cap**



Technical description	
Frame width:	42 mm
Vent width:	18 mm
Wall thickness:	1.6-1.8 mm
The glass thickness width:	8,10,32,34,36 mm
Rubber description:	EPDM DIN 7863
Aluminium alloy extrusion:	EN AW 6063 T5
Thermal barrier:	Polyamide 6.6 GF 25%
Thermal transmittance:	3.59 $\frac{W}{(M^2.K)}$

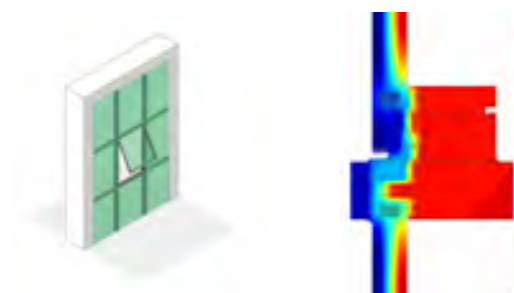
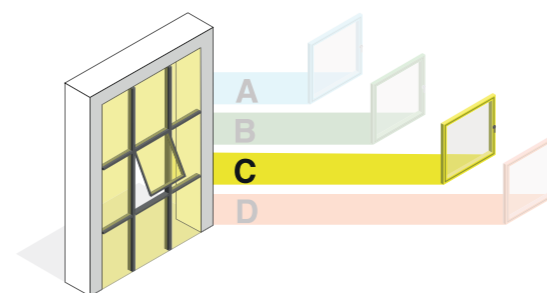

**CURTAIN WALL SYSTEM**

**Opening of U-Channel (SSG) AKV50**



**Technical description**

the glass thickness width 8, 10, 32, 34, 36, ... mm



Polyamides width 15 - 20 mm



Profile view 64 mm



Aluminium extrusion EN AW 6063 T5



Rubber description EPDM DIN 7863

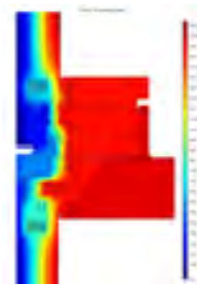
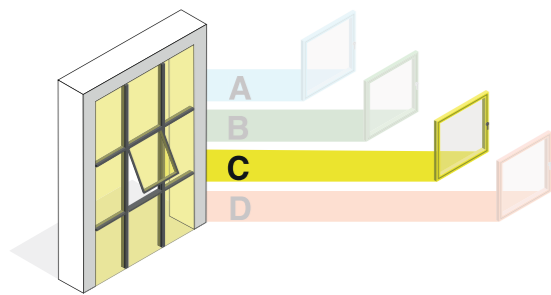

**CURTAIN WALL SYSTEM**

**Opening of U-Channel (SG) AKV50**



**Technical description**

the glass thickness width 8, 10, 32, 34, 36, ... mm



Polyamides width 15 - 20 mm



Profile view 64 mm



Aluminium extrusion EN AW 6063 T5



Rubber description EPDM DIN 7863

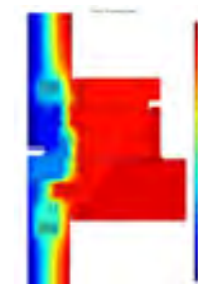
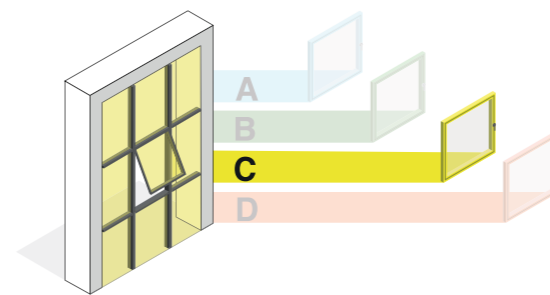



# TABLE OF CONTENT

INTRO ..... 37

UNITIZED FACE CAP AKU65 ..... 38

UNITIZED U-CHANNEL AKU65 ..... 39

## MALUNO UNITIZED AKU 65 SYSTEM

The Maluno Unitize curtain wall system consists of large factory-assembled units that have a shorter manufacturing period and on-site installation time than a curtain wall stick system.

Due to the assembly of the panels in the factory, the quality can be controlled.

## CURTAIN WALL SYSTEM

### Unitized Face cap AKU 65



#### Technical description

The glass thickness width: 20 - 52 mm



Polyamid width: 34 mm



Profile view: 65 mm



Rubber description: EPDM DIN 7863



Aluminium alloy extrusion: EN AW 6063 T5



Thermal barrier: Polyamide 6.6 GF 25%



Thermal transmittance: 2.47  $\frac{W}{(M^2.K)}$

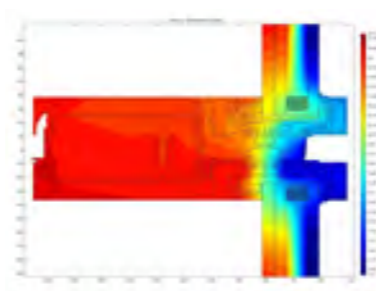
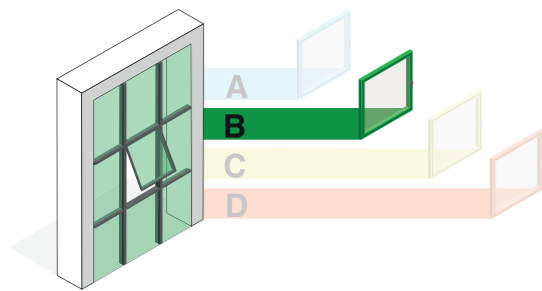

## CURTAIN WALL SYSTEM

### Unitized U-Channel AKU 65



#### Technical description

the glass thickness width 26 - 42 mm



Polyamides width 34 mm



Profile view 65 mm



Aluminium extrusion EN AW 6063 T5



Rubber description EPDM DIN 7863

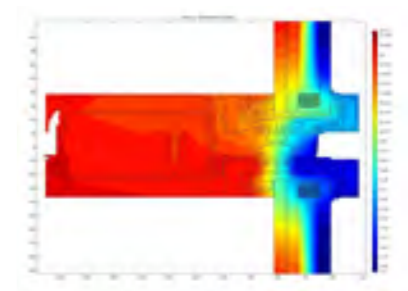
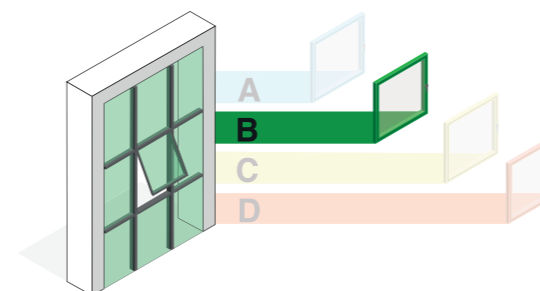



# SLIDING System

## MALUNO SLIDING

An aluminium sliding system is a type of architectural or construction feature made primarily from aluminium and designed to enable sliding movement.

- **Sliding System:** Unlike hinged systems, which operate on hinges and swing open and closed, sliding systems allow for horizontal movement along a track. In the case of aluminium sliding systems, these tracks and accompanying mechanisms are made predominantly from aluminium.
- **Applications:** Aluminium sliding systems find applications in various architectural and construction contexts, including:
  - **Doors:** Aluminium sliding doors are popular in both residential and commercial settings due to their space-saving design and ease of operation.
  - **Windows:** Aluminium sliding windows are commonly used in homes, offices, and commercial buildings, providing easy access to ventilation and natural light.
  - **Partitions:** Aluminium sliding partitions are utilized to create flexible spaces within buildings, such as dividing meeting rooms or creating movable walls in large halls.

**Advantages,** Aluminium sliding systems offer several benefits, including:

- **Space-saving:** Sliding doors and windows don't require swing space, making them ideal for areas with limited room for opening traditional doors or windows.
- **Smooth operation:** Properly designed and installed aluminium sliding systems offer smooth and effortless operation, allowing for easy opening and closing.
- **Durability:** Aluminium's corrosion resistance and strength make it well-suited for outdoor applications and areas with high traffic.
- **Aesthetic appeal:** Aluminium sliding systems can be designed with sleek profiles and large glass panels, providing a modern and stylish look to buildings.
- **Customization:** Aluminium sliding systems can be customized to fit specific design requirements, including size, color, and configuration. This flexibility allows architects and designers to create unique and functional spaces.

Overall, aluminium sliding systems offer a practical, durable, and aesthetically pleasing solution for various architectural and construction needs, particularly where space efficiency and ease of operation are essential considerations.



# TABLE OF CONTENT

INTRO ..... 43

---

LIFT & SLIDE:

**AKL 140 - Base system** ..... 44

**AKL 140 - Zero Threshold** ..... 47

**AKL 140 - Low Threshold** ..... 48

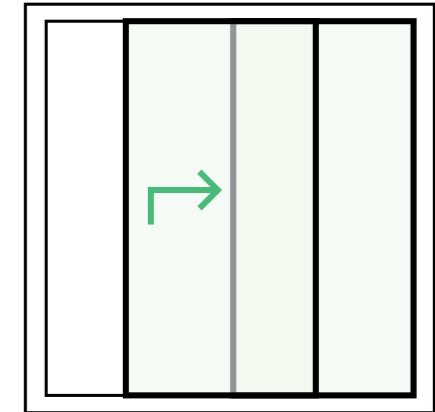

## MALUNO LIFT & SLIDE AKL 140 SYSTEM

This system is a lift opening, the depth of the frame is 140 mm, which allows users to have a transparent opening, AkL140 system has a very good thermal performance.

LIFT & SLIDE SYSTEM

**AKL 140 - Base system**

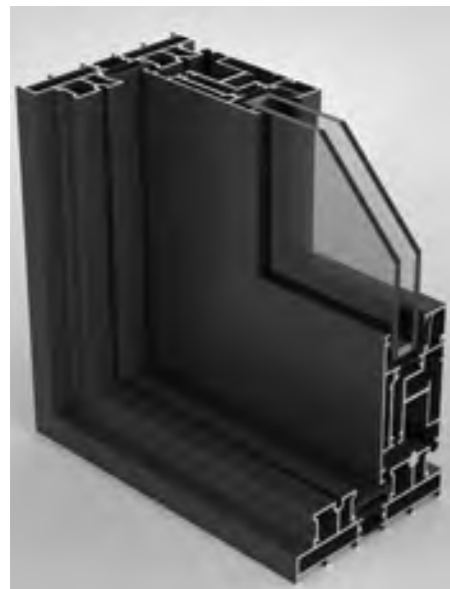

**Technical description**

The glass thickness width: 6-40 mm



Polyamides width: 24 mm



Profile width: 140 mm



Profile view: 144 mm



Rubber description: EPDM DIN 7863



Aluminium alloy extrusion: EN AW 6063 T5



Thermal barrier: Polyamide 6.6 GF 25%

Thermal transmittance: 2.95  $\frac{W}{(M^2.K)}$

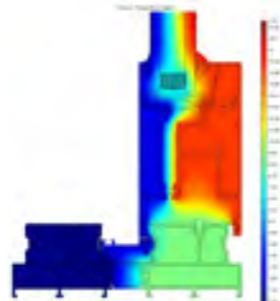
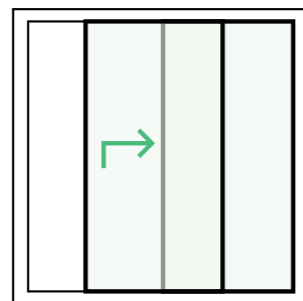
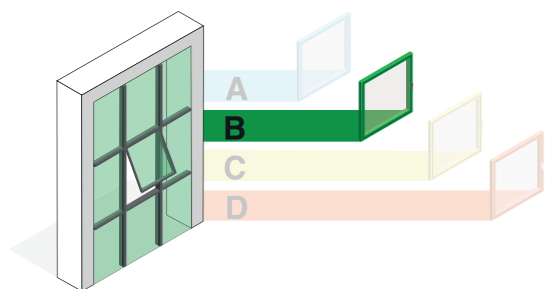

LIFT & SLIDE SYSTEM

**AKL 140 - Sash on the outer rail**



LIFT & SLIDE SYSTEM

**AKL 140 - Sash on the inner rail**

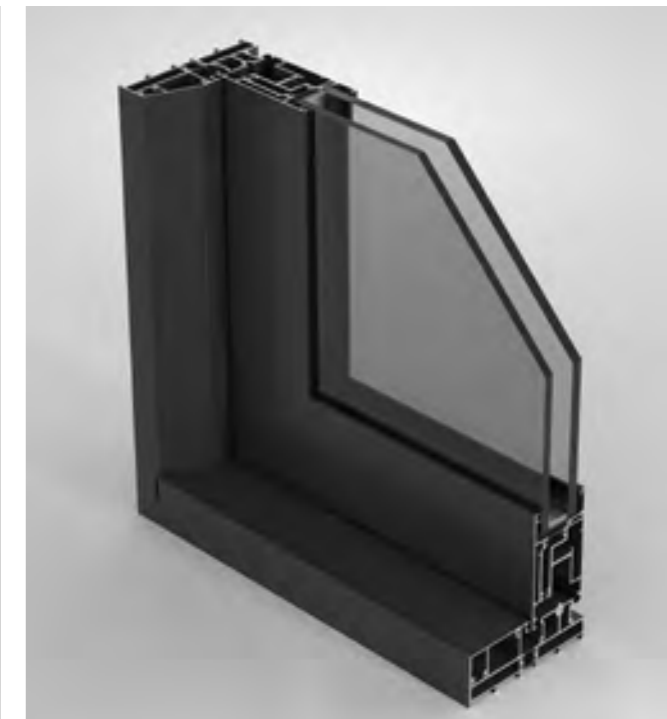

LIFT & SLIDE SYSTEM

**AKL 140 - Triple rail**

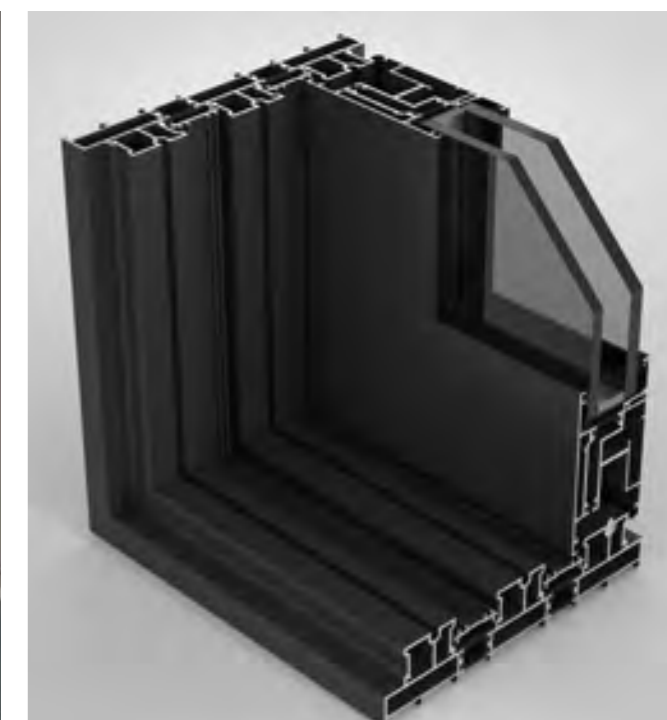

LIFT & SLIDE SYSTEM

AKL 140 - Fix Coupling



LIFT & SLIDE SYSTEM

AKL 140 - Opening Coupling



LIFT & SLIDE SYSTEM

AKL 140 - Zero Threshold



Technical description

The glass thickness width: 6 - 40 mm



Polyamides width: 24 mm



Profile view: 94 mm



Rubber description: EPDM DIN 7863



Aluminium alloy extrusion: EN AW 6063 T5



Thermal barrier: Polyamide 6.6 GF 25%



Thermal transmittance: 2.66  $\frac{W}{(M^2.K)}$

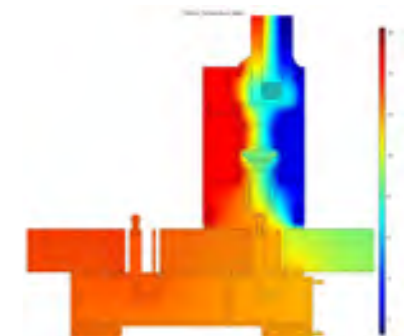
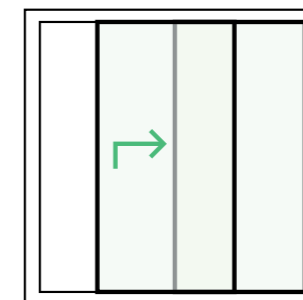
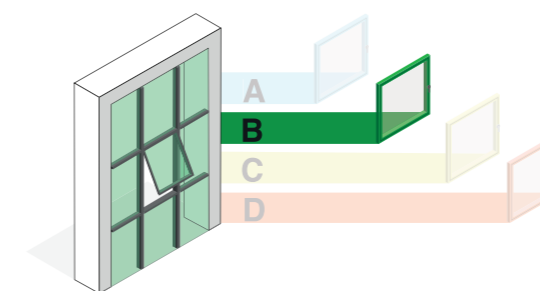



## LIFT & SLIDE SYSTEM

### AKL 140 - Low Threshold



#### Technical description

Frame width:	140 MM
Vent width:	59 MM
Wall thickness:	2-1.8 MM
The glass thickness width:	40-6 MM
Rubber description:	EPDM DIN 7863
Aluminium alloy extrusion:	EN AW 6063 T5
Thermal barrier:	POLYAMIDE 6.6 GF %25
Thermal transmittance:	2.92 $\frac{W}{(M^2.K)}$

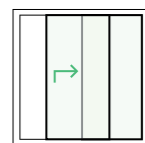
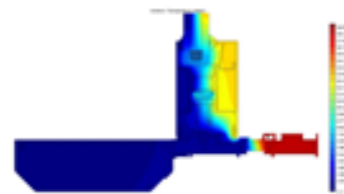
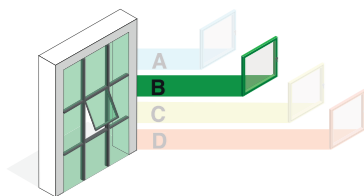



# TABLE OF CONTENT

INTRO ..... 51

LIFT & SLIDE:

**AKS 90** ..... 52

SLIDING:

**AKS 90 - Monorail** ..... 54

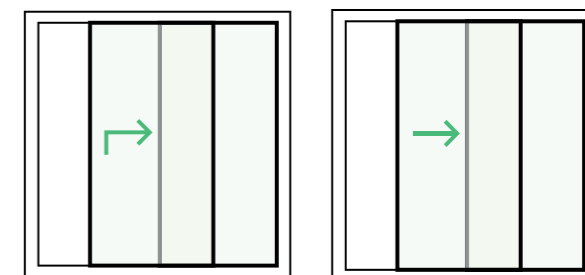

## MALUNO SLIDE, LIFT & SLIDE AKS 90 SYSTEM

This system is a slim lift and slide opening, the depth of the frame is 90 mm, which allows users to have a transparent opening, AKS90 system is economically viable and has acceptable thermal insulation.

**LIFT & SLIDE SYSTEM**

**AKS 90 - Base System**



**Technical description**



Frame width: **90 MM**



Vent width: **38 MM**



Wall thickness: **1.9-1.5 MM**



The glass thickness width: **24-16 MM**



Rubber description: **EPDM DIN 7863**



Aluminium alloy extrusion: **EN AW 6063 T5**



Thermal barrier: **POLYAMIDE 6.6 GF %25**



Thermal transmittance: **3.51  $\frac{W}{(M^2.K)}$**

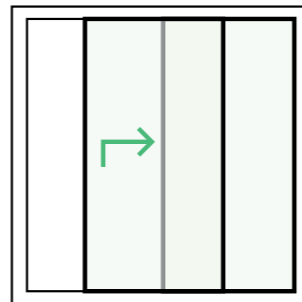
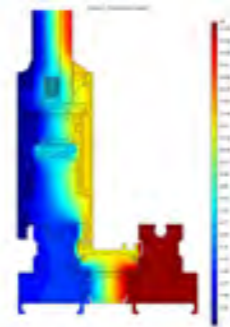
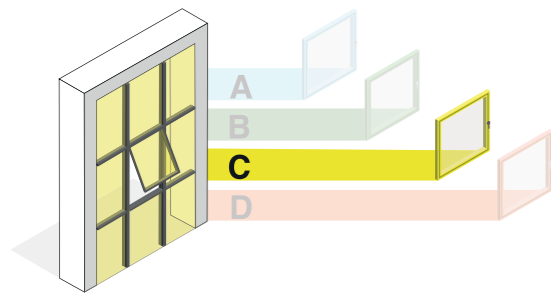

**LIFT & SLIDE SYSTEM**

**AKS 90 - Monorail**

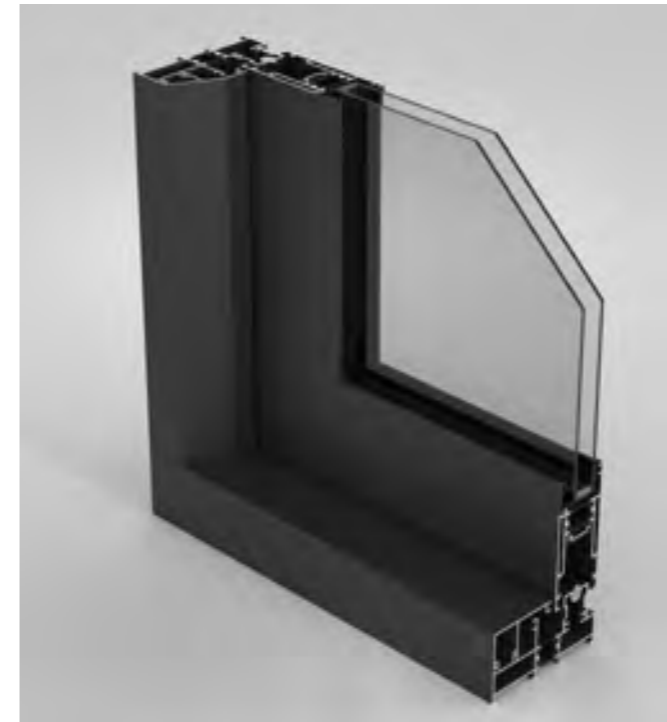

**LIFT & SLIDE SYSTEM**

**AKS 90 - Flat Double rail**

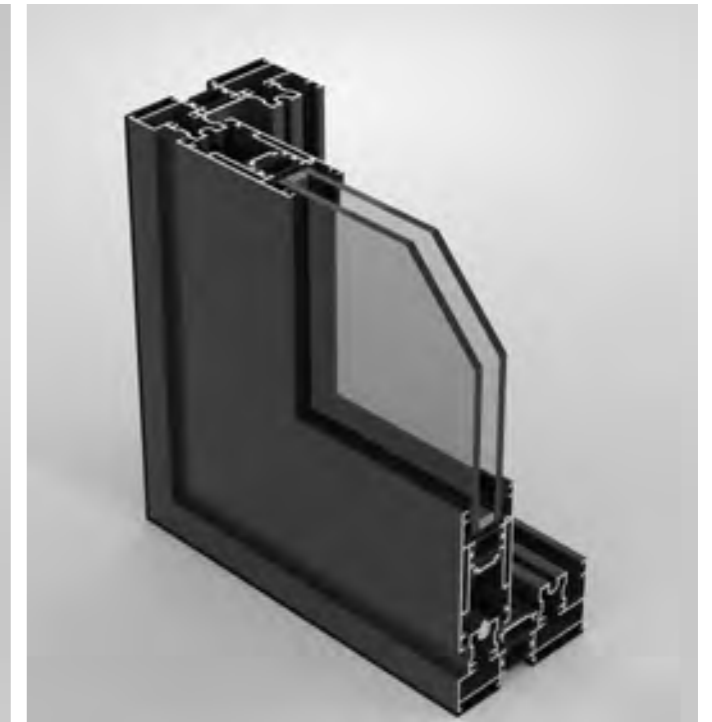

**LIFT & SLIDE SYSTEM**

**AKS 90 - Triple rail**

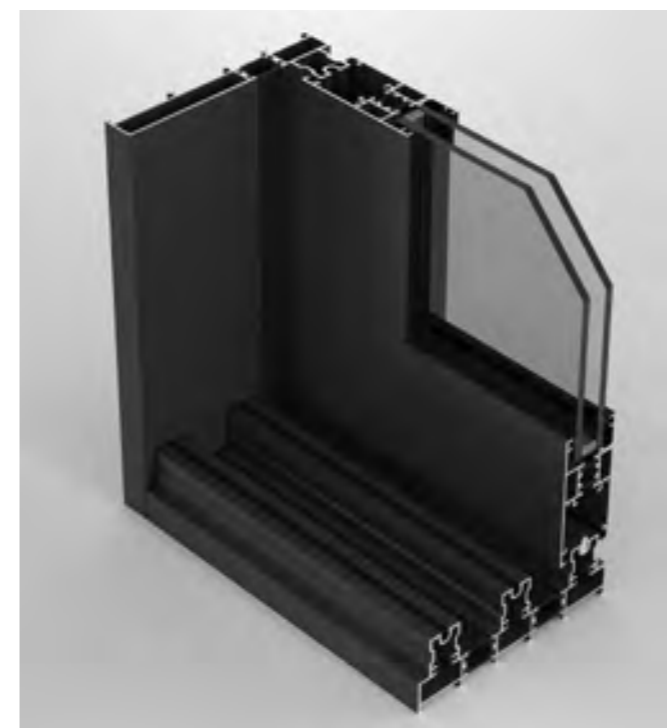

**LIFT & SLIDE SYSTEM**

**AKS 90 - Fix Coupling**



**SLIDING SYSTEM**

**AKS 90 - Flat Double rail**

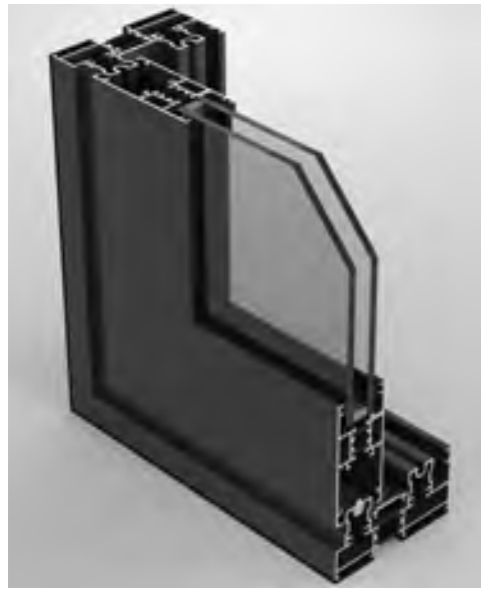

**Technical description**



Frame width: **90 MM**



Vent width: **38 MM**



Wall thickness: **1.9-1.5 MM**



The glass thickness width: **24-16 MM**



Rubber description: **EPDM DIN 7863**



Aluminium alloy extrusion: **EN AW 6063 T5**



Thermal barrier: **POLYAMIDE 6.6 GF %25**



Thermal transmittance: **3.44  $\frac{W}{(M^2.K)}$**

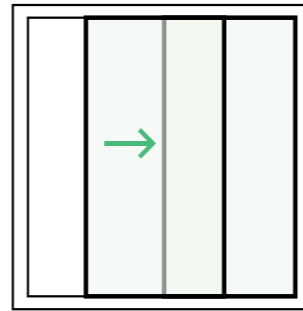
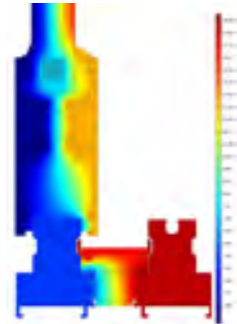
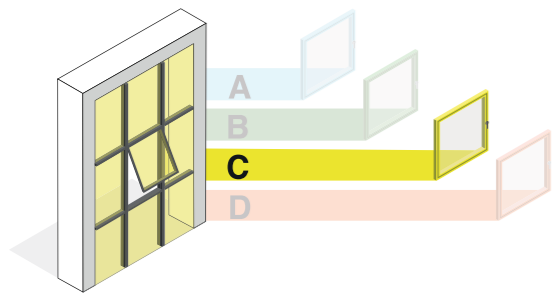

**SLIDING SYSTEM**

**AKS 90 - Monorail**



**SLIDING SYSTEM**

**AKS 90 - Fix Coupling**



**SLIDING, LIFT & SLIDE SYSTEM**

**AKS 90 - Opening Coupling**





# HINGED System

## MALUNO HINGED

Aluminium hinged system is referred to a construction or architectural feature made of aluminium that incorporates hinges for movement or a few operations.

In the case of a hinged system, the objects that are included be doors, windows, gates, or any other components that need to pivot or swing open and closed.

- **Doors and Window:** Aluminium hinged doors and windows are commonly found in commercial buildings, residential properties, popular for their durability, low maintenance, sleek appearance and industrial facilities.
- **Gates:** Aluminium hinged gates provide security and access control for properties such as residential driveway, commercial premises and industrial sites.

**Advantages,** Some of the advantages of aluminium hinged systems include:

- **Durability:** Aluminium is resistant to corrosion, rust, and degradation, making it suitable for outdoor applications.
- **Lightweight section:** Aluminium is much lighter than other metals like steel, making it easier to handle and install.
- **Design flexibility:** Aluminium can be easily fabricated into various shapes and sizes, allowing for custom designs to suit specific architectural requirements.
- **Low maintenance:** Aluminium hinged systems typically require minimal maintenance over their lifespan, reducing long-term costs.

Overall, aluminium hinged systems offer a reliable and versatile solution for a wide range of architectural and construction needs.

# TABLE OF CONTENT

INTRO ..... 59

---

WINDOW:

**AKW 53** ..... 60

DOOR:

---

**AKW 53** ..... 64

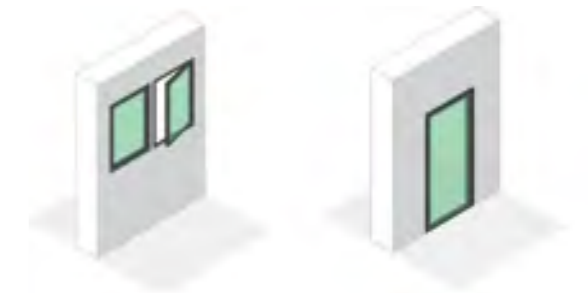
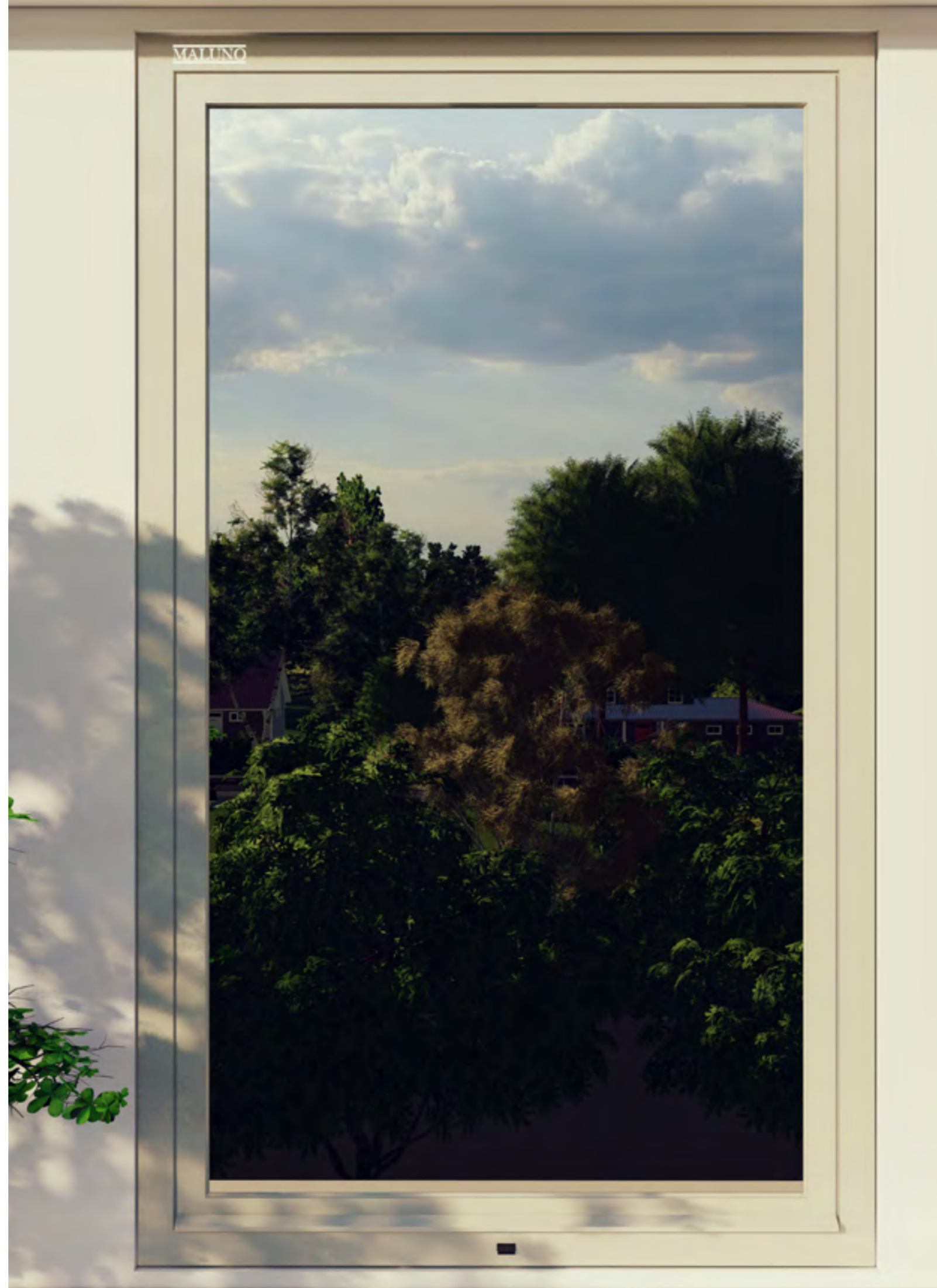

## MALUNO WINDOW & DOOR AKW 53 SYSTEM

A clean and minimalistic look, sustainable for all architectural styles. This system has 53 mm frame depth thermal performance allows architects to use an economic and standard system in buildings.

**WINDOW SYSTEM**

**AKW 53 - Tilt & Turn Type 1**



**Technical description**



Frame width: **53 MM**



Vent width: **61 MM**



Wall thickness: **1.5 MM**



The glass thickness width: **42-16 MM**



Rubber description: **EPDM DIN 7863**



Aluminium alloy extrusion: **EN AW 6063 T5**



Thermal barrier: **POLYAMIDE 6.6 GF %25**



Thermal transmittance: **2.31  $\frac{W}{(M^2.K)}$**

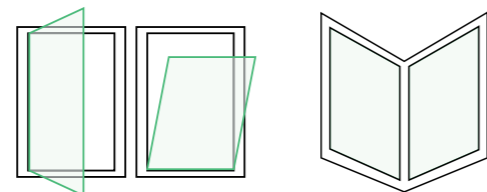
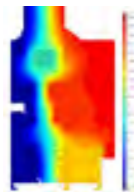
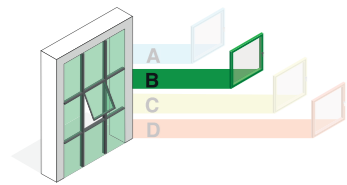

**WIINDOW SYSTEM**

**AKW 53 - Tilt & Turn Type 2**



**WINDOW SYSTEM**

**AKW 53 - Tilt & Turn Type 3**

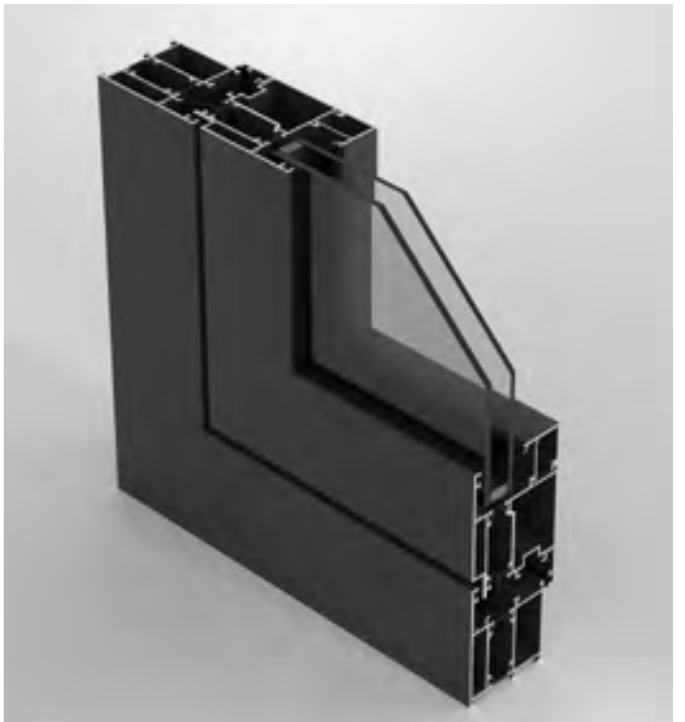

DOOR & WINDOW SYSTEM

**AKW 53 - Grill**



DOOR & WINDOW SYSTEM

**AKW 53 - Thermal Break Grill**



DOOR & WINDOW SYSTEM

**AKW 53 - Normal Grill**



WINDOW & DOOR SYSTEM

**AKW 53 - Coupling Type 1**



WINDOW & DOOR SYSTEM

**AKW 53 - Coupling Type 2**



WINDOW & DOOR SYSTEM

**AKW 53 - Coupling Type 3**





**DOOR SYSTEM**

**AKW 53 - Flat Inward**



**Technical description**



Frame width: 53 mm



Vent width: 53 mm



Threshold width: 37 - 45 mm



Wall thickness: 1.5 - 2 mm



The glass thickness width: 20 - 38 mm



Rubber description: EPDM DIN 7863



Aluminium alloy extrusion: EN AW 6063 T5



Thermal barrier: Polyamide 6.6 GF 25%

Thermal transmittance: 2.92  $\frac{W}{(M^2.K)}$

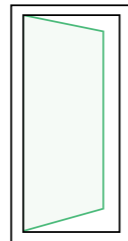
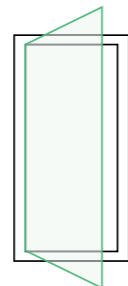
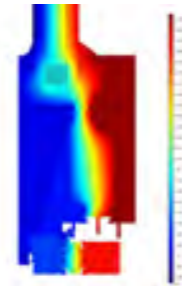
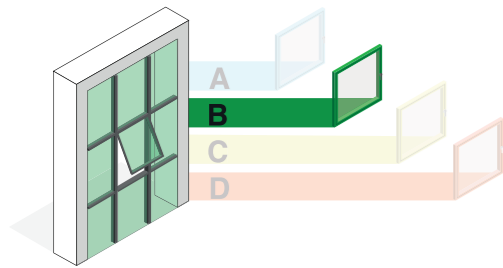

**DOOR SYSTEM**

**AKW 53 - Eure groove Outward**



**DOOR SYSTEM**

**AKW 53 - Eure groove Inward**





# TABLE OF CONTENT

INTRO .....	67
<hr/>	
WINDOW:	
<b>AKW 63</b> .....	68
<hr/>	
DOOR:	
<b>AKW 63</b> .....	72

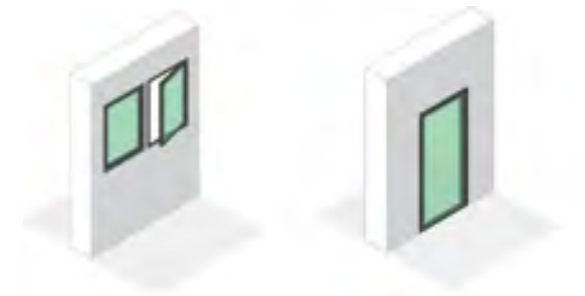

## MALUNO WINDOW & DOOR AKW 63 SYSTEM

This system has 63 mm frame depth and better thermal performance compared to the AKW53 system.

**WINDOW SYSTEM**

**AKW 63 - Tilt & Turn Type 1**



**Technical description**



Frame width: **63 MM**



Vent width: **71 MM**



Wall thickness: **1.5 MM**



The glass thickness width: **52-20 MM**



Rubber description: **EPDM DIN 7863**



Aluminium alloy extrusion: **EN AW 6063 T5**



Thermal barrier: **POLYAMIDE 6.6 GF %25**



Thermal transmittance: **1.69 W/(m<sup>2</sup>.K)**

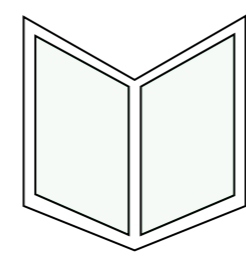
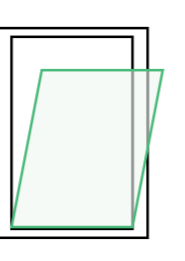
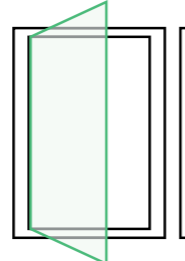
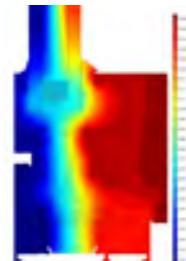
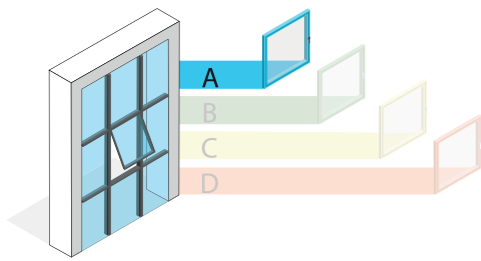

**WINDOW SYSTEM**

**AKW 63 - Tilt & Turn Type 2**



**WINDOW SYSTEM**

**AKW 63 - Tilt & Turn Type 3**

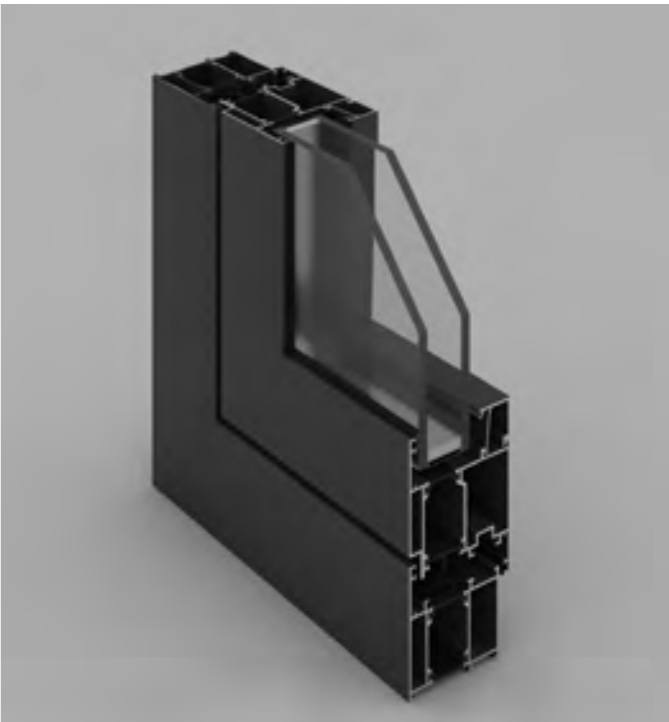

**WINDOW SYSTEM**

**AKW 63 - Rainforce**

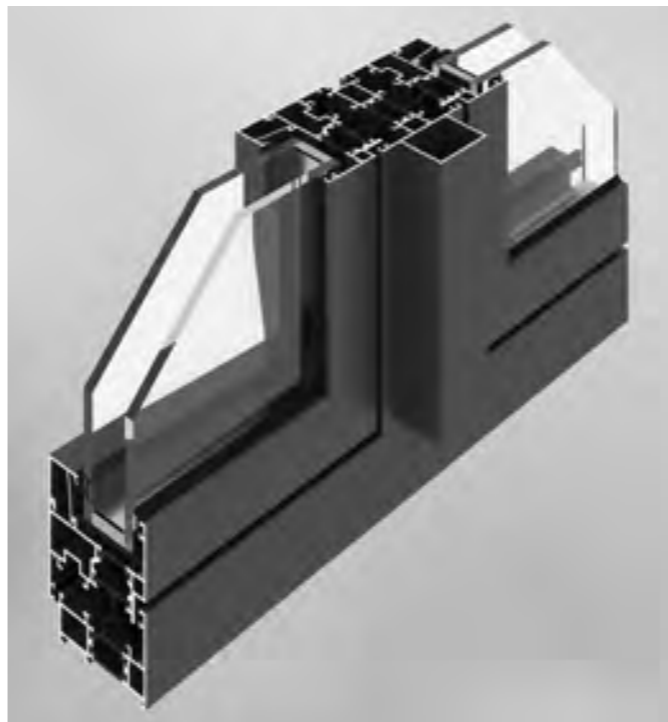

**WINDOW SYSTEM**

**AKW 63 - French**



**DOOR & WINDOW SYSTEM**

**AKW 63 - Grill**



**DOOR & WINDOW SYSTEM**

**AKW 63 - Thermal Break Grill**



**WINDOW & DOOR SYSTEM**

**AKW 63 - Coupling Type 1**

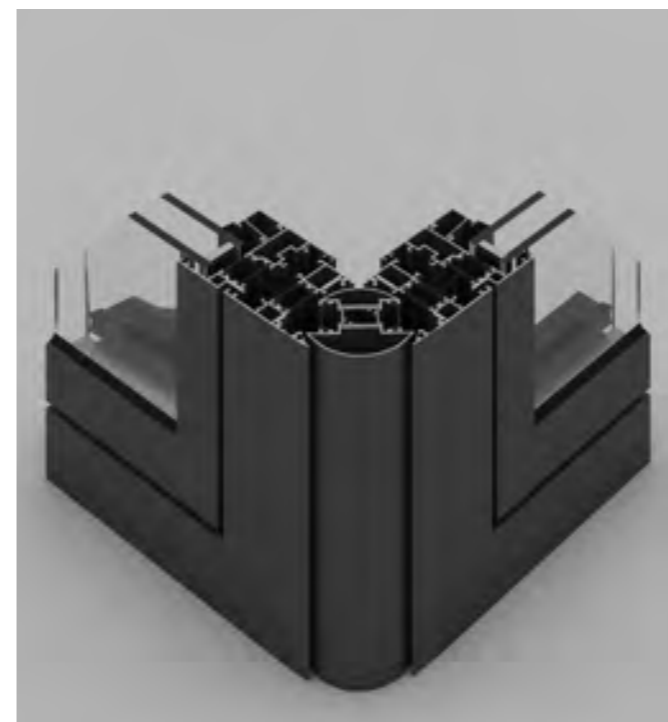

**WINDOW & DOOR SYSTEM**

**AKW 63 - Coupling Type 2**

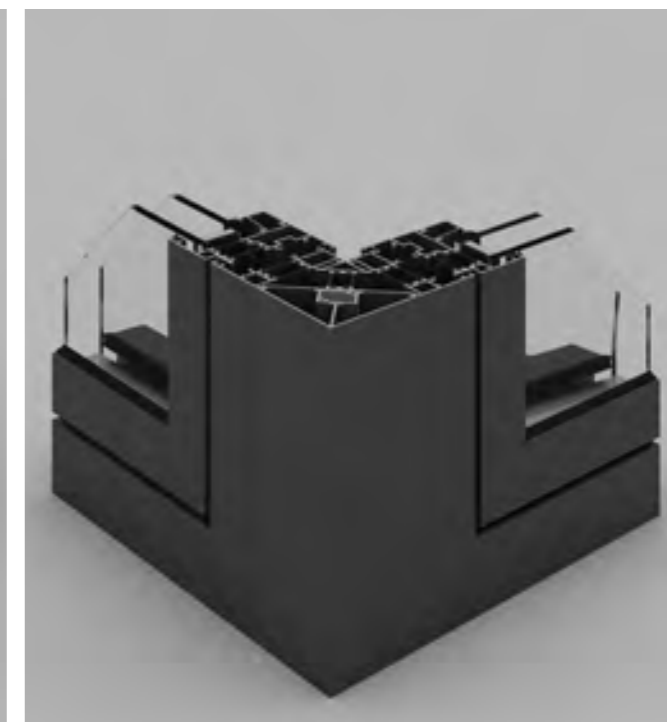

**DOOR & WINDOW SYSTEM**

**AKW 63 - Normal Grill**

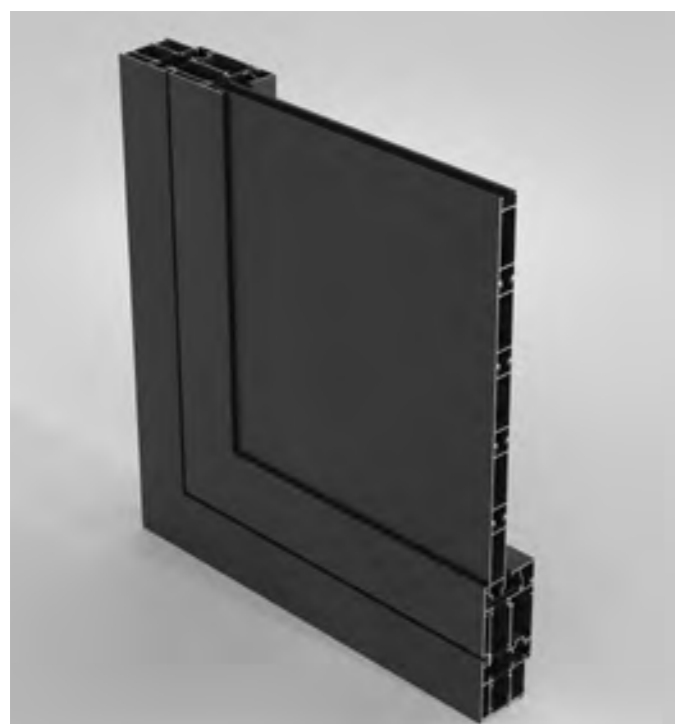

**WINDOW & DOOR SYSTEM**

**AKW 63 - Coupling Type 3**

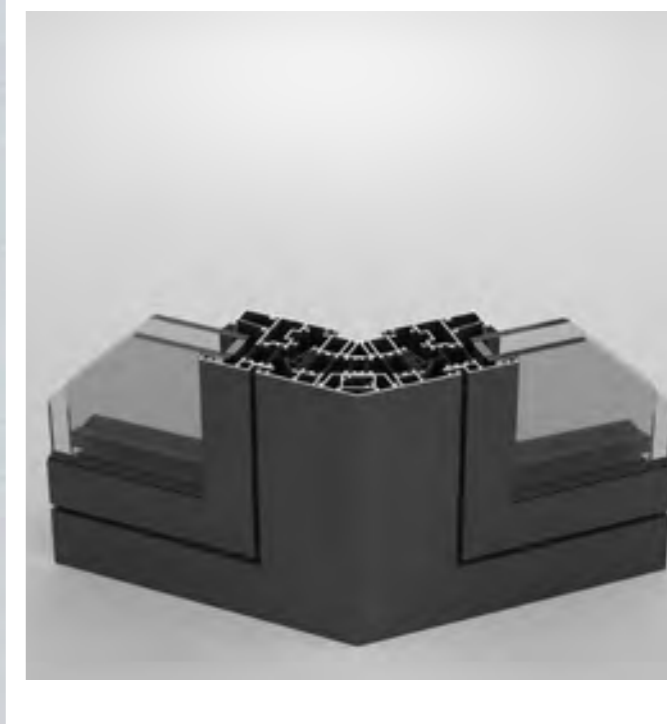

**DOOR SYSTEM**

**AKW 63 - Flat Inward**



**Technical description**



Frame width: 63 mm



Vent width: 63 mm



Threshold width: 47-55 mm



Wall thickness: 1.5-2 mm



The glass thickness width: 20-48 mm



Rubber description: EPDM DIN 7863



Aluminium alloy extrusion: EN AW 6063 T5



Thermal barrier: Polyamide 6.6 GF 25%

Thermal transmittance: 2.25  $\frac{W}{(M^2.K)}$

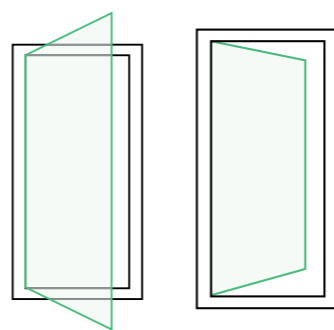
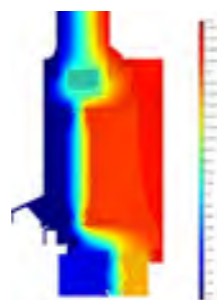
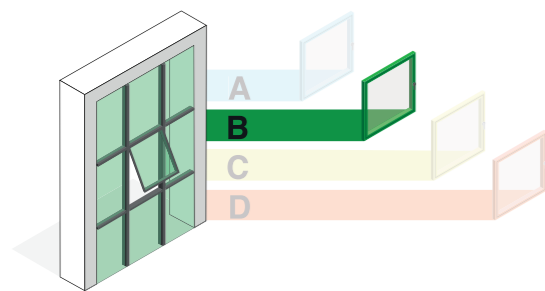

**DOOR SYSTEM**

**AKW 63 - Flat Outward**



**DOOR SYSTEM**

**AKW 63 - Eure Groove Inward**



**DOOR SYSTEM**

**AKW 63 - Eure Groove Outward**



# TABLE OF CONTENT

INTRO ..... 75

WINDOW:

**AKW 73** ..... 56

DOOR:

**AKW 73** ..... 79

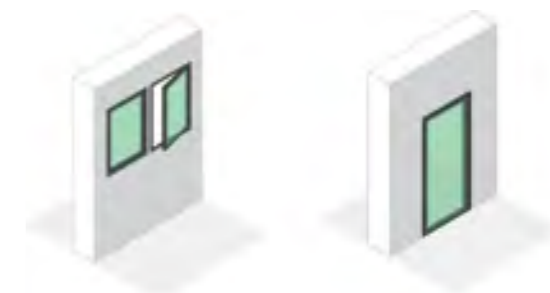

## MALUNO WINDOW & DOOR AKW 73 SYSTEM

This system has 73 mm frame depth. Thermal performance was improved thanks to stronger polyamides.

## WINNOW SYSTEM

### AKW 73 - Tilt & Turn Type 1



#### Technical description



The glass thickness width: 54-20 MM



Polyamides width: 34 MM



Profile width: 73 MM



Profile view: 46 MM



Rubber description: EPDM DIN 7863



Aluminium alloy extrusion: EN AW 6063 T5



Thermal barrier: POLYAMIDE 6.6 GF %25



Thermal transmittance: 1.61  $\frac{W}{(M^2.K)}$

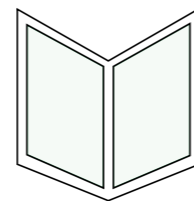
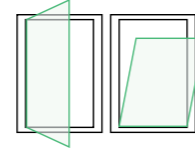
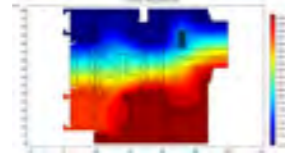
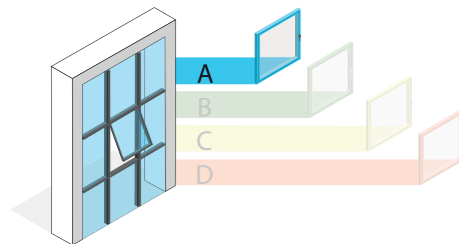

## WINNOW SYSTEM

### AKW 73 - Tilt & Turn type 2

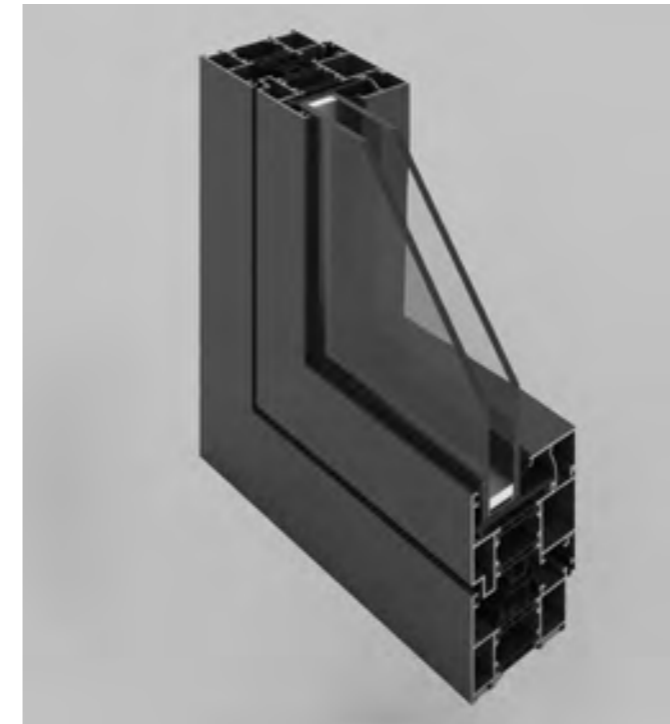

## WINNOW SYSTEM

### AKW 73 - Tilt & Turn Type 3

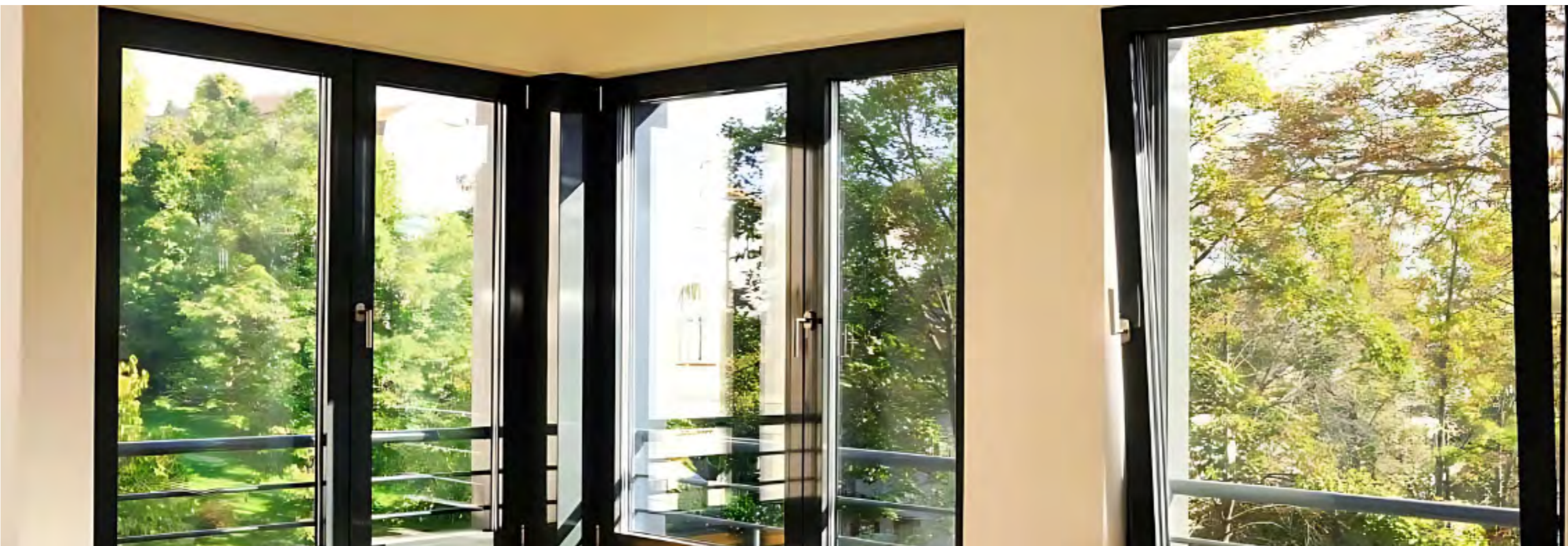

**WINDOW & DOOR SYSTEM**

**AKW 73 - Coupling Type 1**



**WINDOW & DOOR SYSTEM**

**AKW 73 - Coupling Type 2**



**WINDOW & DOOR SYSTEM**

**AKW 73 - Coupling Type 3**



**DOOR SYSTEM**

**AKW 73 - Flat Inward**



**Technical description**

Frame width:	73 MM
Vent width:	73 MM
Threshold width:	65-57 MM
Wall thickness:	2-1.5 MM
The glass thickness width:	54-20 MM
Rubber description:	EPDM DIN 7863
Aluminium alloy extrusion:	EN AW 6063 T5
Thermal barrier:	POLYAMIDE 6.6 GF %25

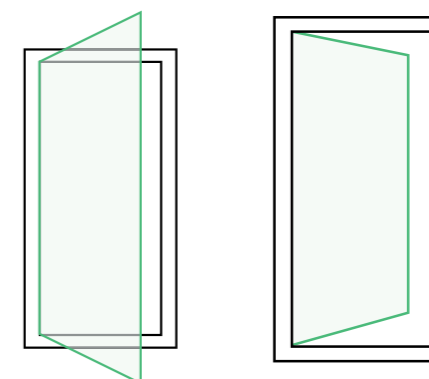
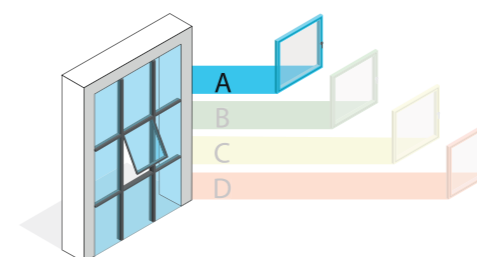



DOOR SYSTEM

**AKW 73 - Flat Outward**

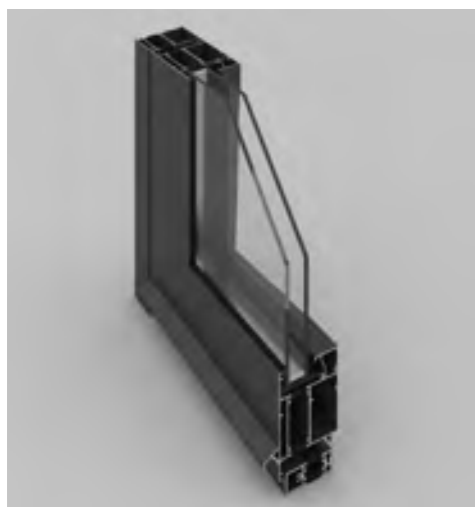

DOOR SYSTEM

**AKW 73  
Euro Groove Inward**

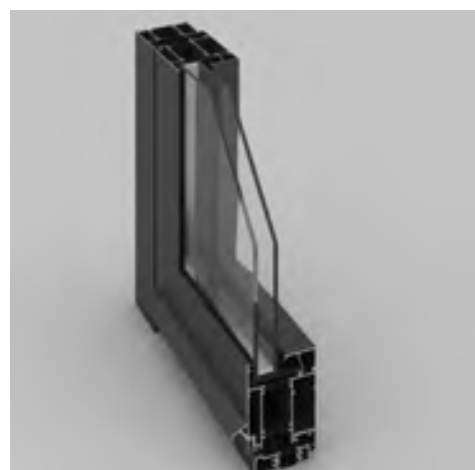

DOOR SYSTEM

**AKW 73  
Euro Groove Outward**

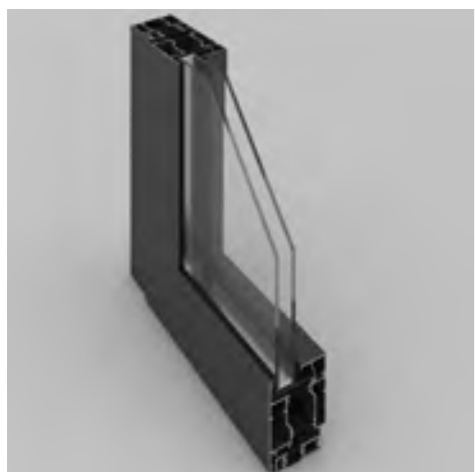

# TABLE OF CONTENT

INTRO ..... 82

HIDDEN VENT WINDOW:

**AKH** ..... 83

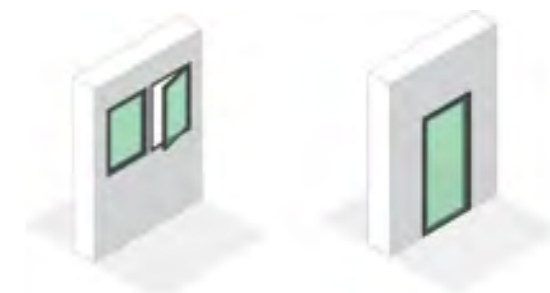

## MALUNO HIDDEN VENT WINDOW AKH SYSTEM

The vents are covered by the outer frames and transoms, which allows for a concealed install of the elements of the window behind the window reveal.

## HIDDEN VENT WINNOW SYSTEM

### AKH - 53



#### Technical description

the glass thickness width: 24 - 38 mm



Polyamides width: 14 mm



Profile width: 53 mm



Profile view: 76 mm



Aluminium extrusion: EN AW 6063 T5



Rubber description: EPDM DIN 7863

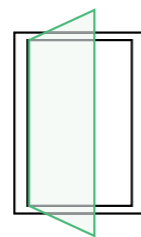
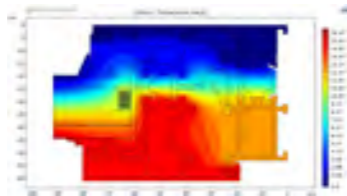
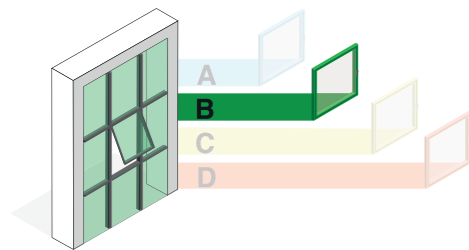

## HIDDEN VENT WINNOW SYSTEM

### AKH - 63

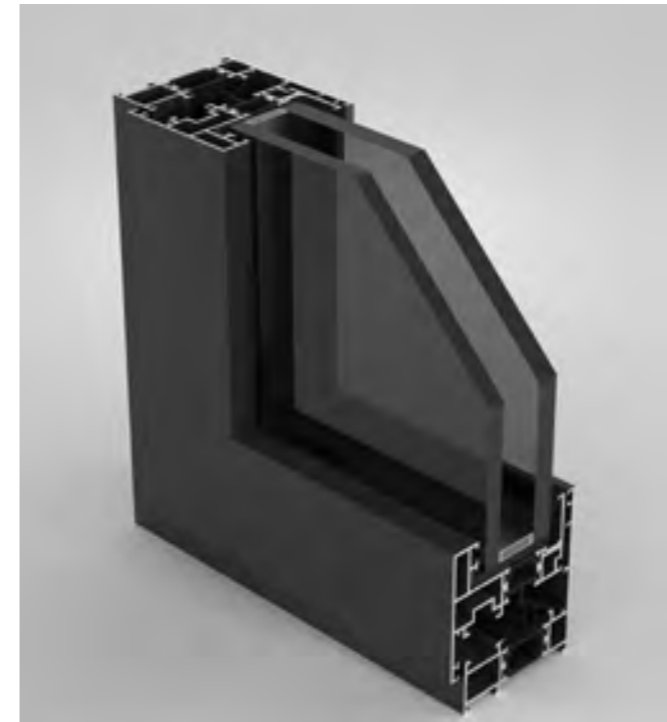

#### Technical description

the glass thickness width: 24 - 38 mm

Polyamides width: 14 mm

Profile width: 63 mm

Profile view: 76 mm

Aluminium extrusion: EN AW 6063 T5

Rubber description: EPDM DIN 7863

## HIDDEN VENT WINNOW SYSTEM

### AKH - 73

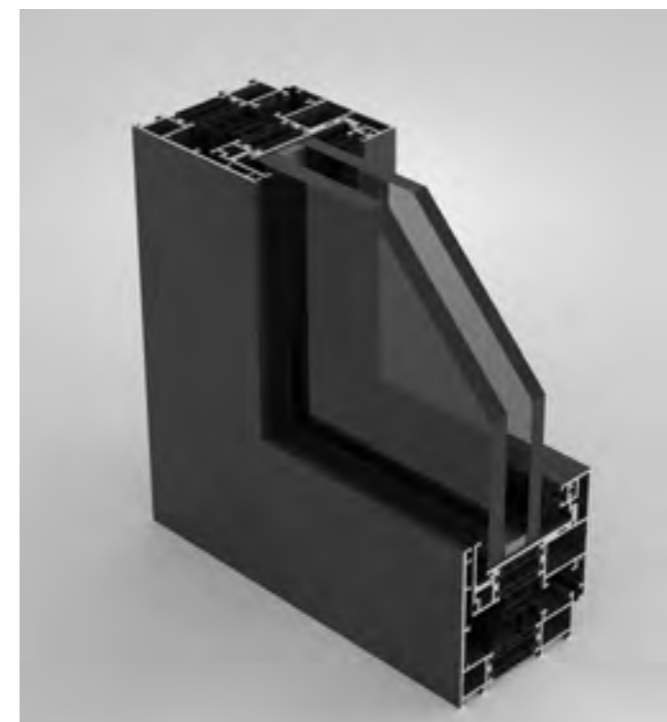

#### Technical description

the glass thickness width: 24 - 38 mm

Polyamides width: 14 mm

Profile width: 73 mm

Profile view: 76 mm

Aluminium extrusion: EN AW 6063 T5

Rubber description: EPDM DIN 7863

HIDDEN VENT WINNOWER SYSTEM

**AKH - Rainforce**

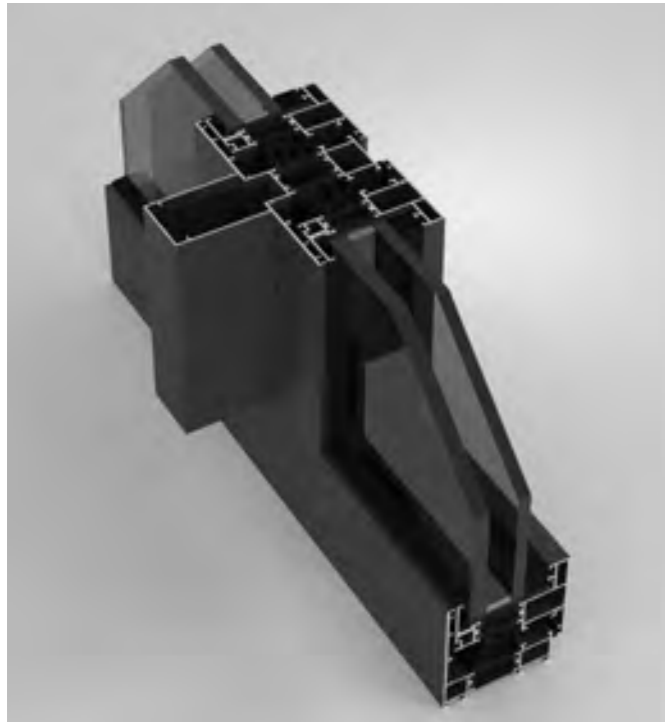

HIDDEN VENT WINNOWER SYSTEM

**AKH - Coupling Type 1**



HIDDEN VENT WINNOWER SYSTEM

**AKH - Grill**

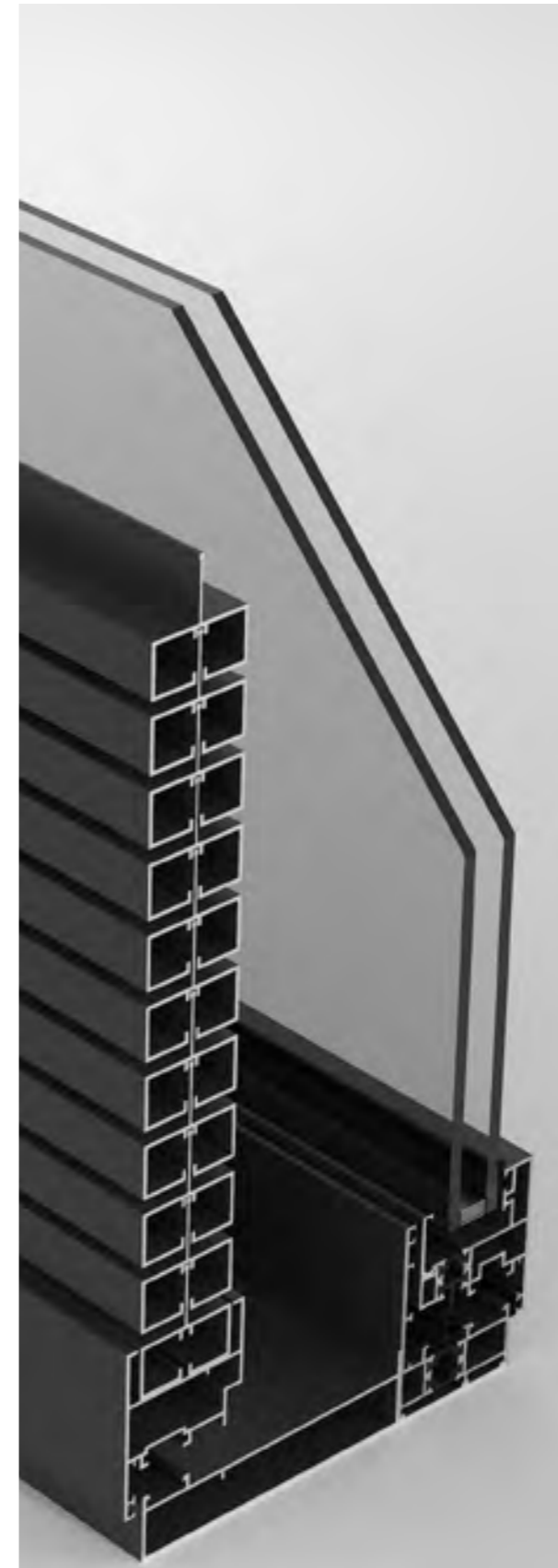

HIDDEN VENT WINNOWER SYSTEM

**AKH - Coupling Type 2**



HIDDEN VENT WINNOWER SYSTEM

**AKH - Coupling Type 3**

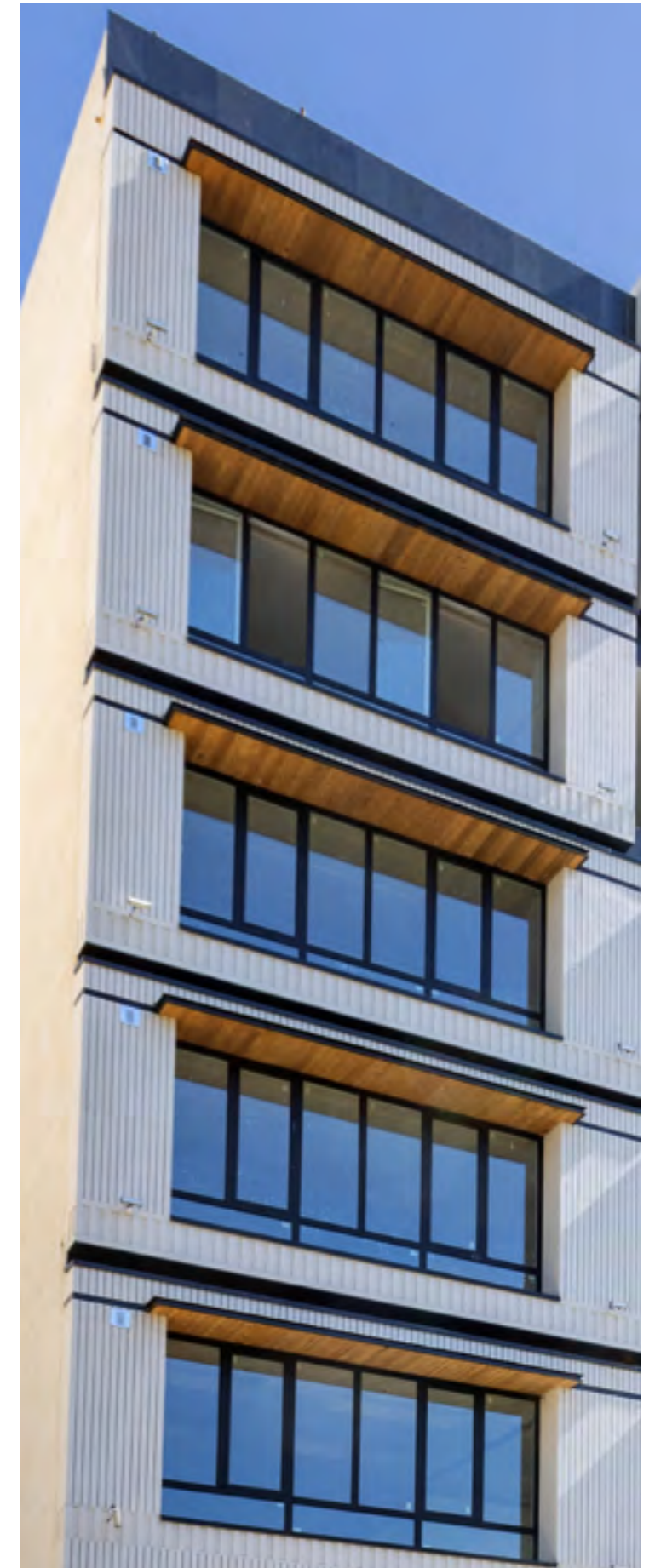



# INTERIOR System (Partition)

## MALUNO INTERIOR SYSTEM (Partition)

Partition means division and separation. By using various types of aluminium partitions, you can use up the space properly and systematically. For example, by dividing large spaces into several smaller parts, you can perform a different function in each one, which aims to organize the space how it can also be alternated or moved in the future. Whenever aluminium frames are used in its design and construction, it is called an aluminium partition, which can be designed and implemented as a single-walled and double-walled ones.

Due to the use of aluminium metal, which has features such as lightness, high strength and ease of movement, you can benefit greatly from this design. The most prominent point of aluminium partitions is their resistance to temperature and humidity changes. They are also recyclable.

Among the types of partitions, we recommend that you choose the aluminium type because it is both very popular and meets the needs of most people in every field. It is also considered the best option and choice at work and home because it is one of the cheapest among the types of partitions.

**PARTITION SYSTEM**

**SINGLE Glass - Four Sided**



**PARTITION SYSTEM**

**DOUBLE Glass - Four Sided**



**PARTITION SYSTEM**

**DOUBLE Glass - Four Sided**

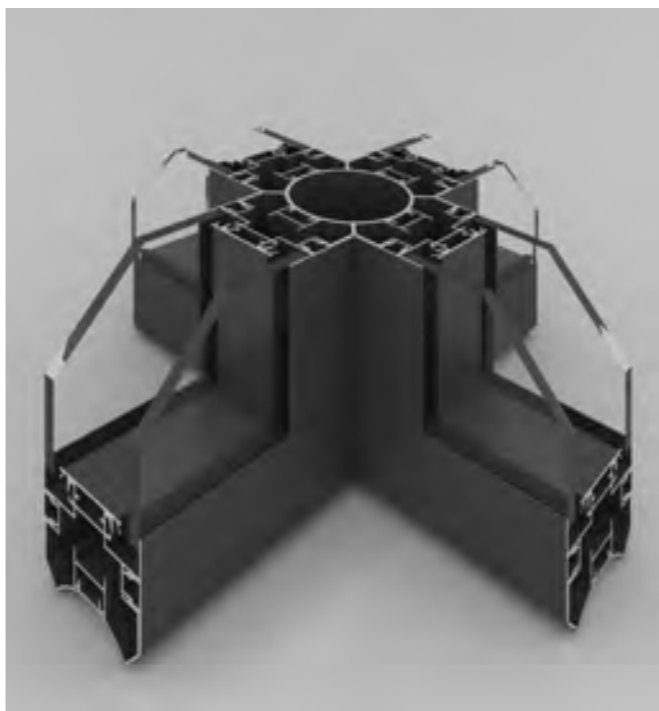

**PARTITION SYSTEM**

**DOUBLE Glass - Three Sided**



**PARTITION SYSTEM**

**SINGLE Glass - Slim Door**



**PARTITION SYSTEM**

**SINGLE Glass - Jointing to Wall**



**PARTITION SYSTEM**

**SINGLE Glass - Frameless Door**



**PARTITION SYSTEM**

**DOUBLE Glass with Door**

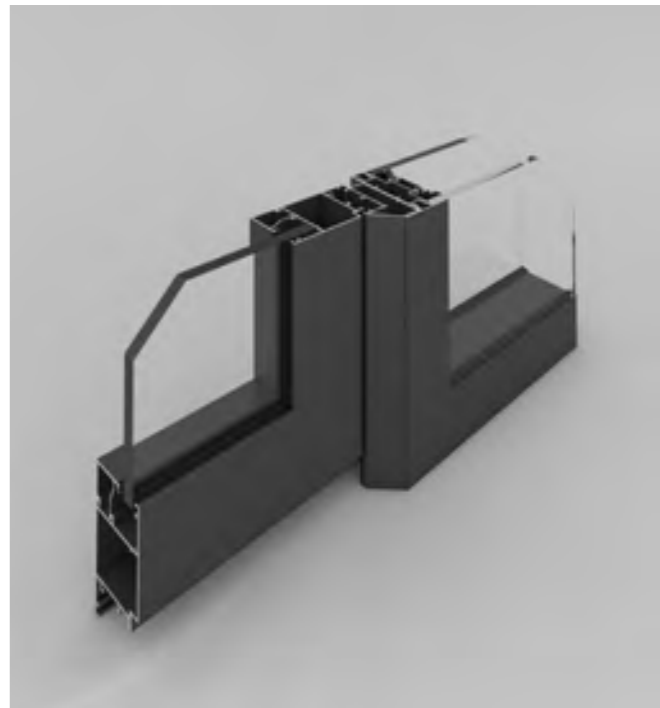



## Sanaye Alumroll Novin Co.

---



+98 86 3355 4404



[www.alumroll.com](http://www.alumroll.com)



@alumrollnovin.co



+98 86 3313 4050



[info@alumroll.com](mailto:info@alumroll.com)



@Alumroll

---

Producer of aluminium Profiles for thermal break doors, windows and curtain wall, unitized facade system as well as all kind of dry systems with Akroll brand.

